

# Operating and safety instructions.

## Motorised lift-and-slide door.

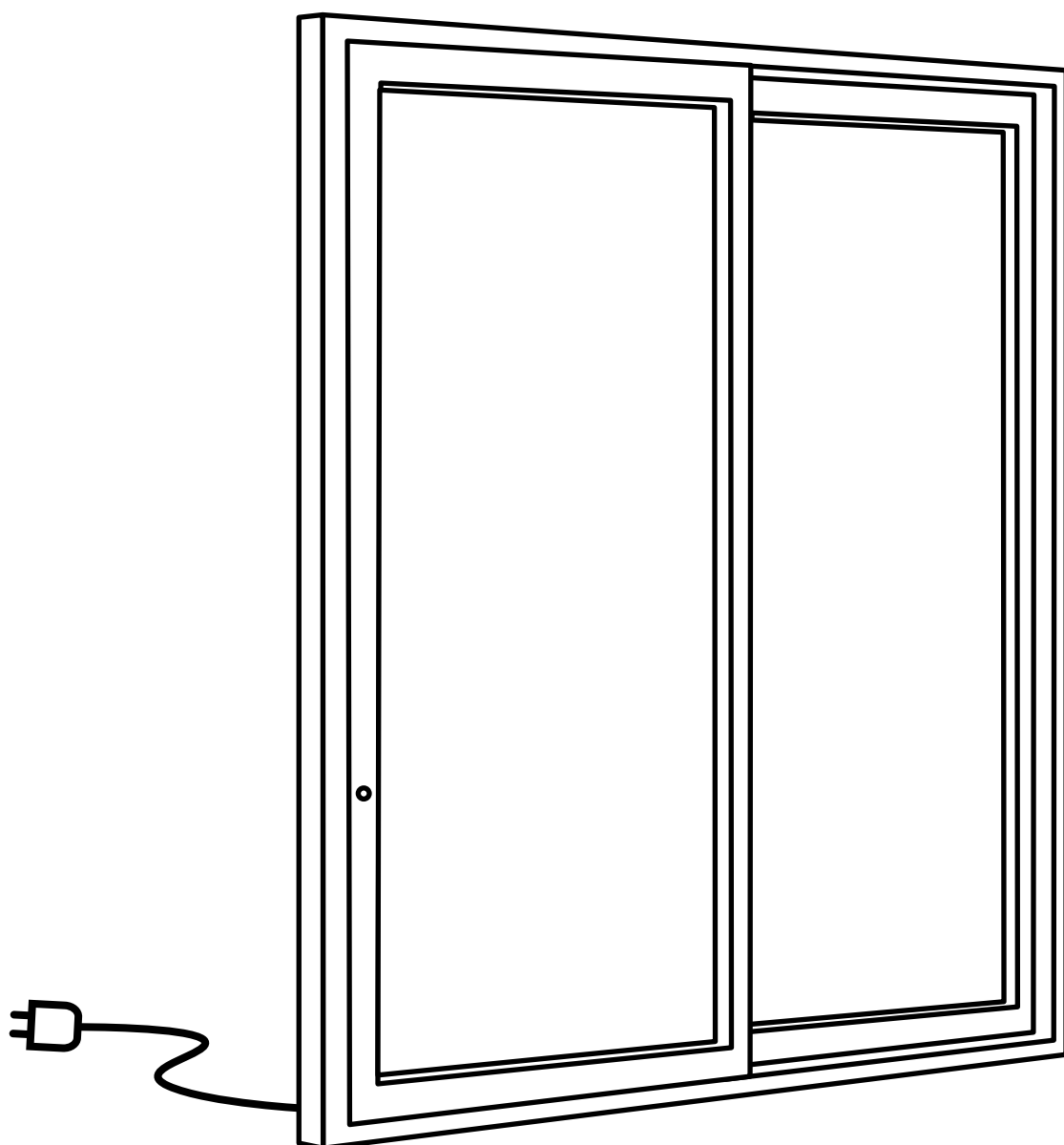



## Table of contents

<b>1</b>	<b>ABOUT THIS DOCUMENTATION</b>	<b>5</b>
1.1	Original operating instructions	5
1.2	Read the instructions	5
1.3	Producer	5
1.4	Target group	5
1.5	Other relevant information	5
1.6		??
1.6.1	Status LED battery pack	6
1.6.2	Light ring operator push button	6
<b>2</b>	<b>SAFETY</b>	<b>7</b>
2.1	Designated use	7
2.2	Requirements for the target groups	7
2.2.1	Producers of construction elements	7
2.2.2	Fitters and retrofitters	8
2.3	Safety information	8
<b>3</b>	<b>PRODUCT SPECIFICATIONS</b>	<b>9</b>
3.1	Scope of delivery	9
3.2	Label	11
3.3	Operating and display elements	12
3.3.1	Status indicator and menu button on the battery pack axxent LS	12
3.3.2	Operator push button axxent LS	13
3.4	Operation	13
3.4.1	Functions of the operator push button	13
3.4.2	Functions of the battery pack	14
3.4.3	Querying the charge status of the battery pack	15
3.4.4	Status monitoring	15
3.4.5	Jam protection	16
3.5	Menu	16
3.5.1	Menu level principle	16
3.5.2	Menu selection	17
3.6	Processing dimensions	20
3.6.1	Hardware size range	20
3.6.2	Drilling dimensions for the operator push button	21
3.6.3	Milling dimensions for the battery pack and the lift drive	22
3.6.4	Drilling dimensions for the cable connection	23
3.6.5	Milling dimension for slide drive	23
3.6.6	Milling dimensions for the catch	24
3.6.7	Drilling dimensions for the CUBE sockets	25
3.6.8	Drilling dimensions for the coupling shoe	26
3.6.9	Drilling dimension for the charging cable	26
3.7	Electrical connection	27
3.7.1	Connecting the lift and slide element to the electricity grid	27
3.7.2	Function control of the charging contact	28
3.7.3	Charging a single battery pack	29
3.7.4	Use of the power pack corrector	30
3.8	Technical specifications	30
<b>4</b>	<b>INSTALLATION</b>	<b>31</b>
4.1	Tools and work equipment	31
4.2	Preparing for installation	32
4.3	Assembling the frame parts	32

4.3.1	Overview of the assembly sequence . . . . .	32
4.3.2	Assembly of frame parts in the guiding rail . . . . .	34
4.4	Processing sliding sashes . . . . .	41
4.4.1	Holes for the button panel profile version Classic and Standard . . . . .	41
4.4.2	Holes for the button panel profile version slim . . . . .	44
4.4.3	Holes for the cable connection coupling shoe/battery . . . . .	45
4.4.4	Holes for the coupling shoe profile version Classic and Standard . . . . .	46
4.4.5	Holes for the coupling shoe profile version slim . . . . .	47
4.5	Installing leaf parts . . . . .	49
4.5.1	Installing the lift drive and the operator push button . . . . .	49
4.5.2	Installing the coupling shoe in the profile version Classic and Standard . . . . .	52
4.5.3	Installing the coupling shoe in the profile version slim . . . . .	54
4.5.4	Installation of the battery pack . . . . .	57
4.5.5	Pairing the battery pack with the lift drive . . . . .	59
<b>5</b>	<b>COMMISSIONING WORKSHOP/INSTALLATION SITE . . . . .</b>	<b>61</b>
5.1	Inserting the sliding sash into the frame . . . . .	61
5.2	Operator push button functions by modes . . . . .	62
5.2.1	Pairing mode . . . . .	62
5.2.2	Processor mode . . . . .	62
5.2.3	Operator mode . . . . .	62
5.3	Pairing the battery pack with the lift and slide drive . . . . .	63
5.4	Perform reference run . . . . .	64
5.5	Not symmetrical fixed sash . . . . .	66
5.6	Performing a teach-in run . . . . .	67
5.7	Attaching the sticker . . . . .	69
5.8	Transferring the lift and slide element to the installation site . . . . .	70
<b>6</b>	<b>TROUBLESHOOTING . . . . .</b>	<b>71</b>
6.1	Troubleshooting . . . . .	71
6.2	Operating limitations in case of low charge status of battery pack (battery pack runs down when sash is open) . . . . .	72
6.3	Emergency release in the event of drive failure . . . . .	73
<b>7</b>	<b>COMPLIANCE . . . . .</b>	<b>74</b>
7.1	EU Declaration of incorporation . . . . .	74

## 1 About this documentation

### 1.1 Original operating instructions

These instructions are part of the original operating instructions. The operating instructions consist of the following sections:

- assembly instructions
- operating and service instructions

### 1.2 Read the instructions

These instructions are an important document and part of the product. Only the defined procedures are safe. Persons can be injured or material damage could occur if these instructions are not observed.

Read and observe the instructions completely prior to the installation of the product.

### 1.3 Producer

SIEGENIA-AUBI KG  
Industriestraße 1 – 3  
57234 Wilnsdorf  
Germany

You can find the addresses of our worldwide locations here: [siegenia.com/company/locations](https://siegenia.com/company/locations)

Entry in the Commercial Register:

- Registry court: Siegen District Court
- Register number: HRA 3741

### 1.4 Target group

This information is intended for producers of construction elements, fitters and retrofitters.

Producers of construction elements are considered to be all those who perform the following activities:

- fabricate SIEGENIA products in window elements or door elements

Fitters and retrofitters include all persons who carry out the following activities:

- SIEGENIA install and repair products in a building project
- retrofit window elements or door elements with SIEGENIA products

### 1.5 Other relevant information

Refer to the following other relevant information prior to installation.

- Safety data sheet in accordance with Regulation (EC) No. 1907/2006, Article 31
- DIN ISO 2768-1:1991-06 General tolerances

- Directive "Hardware for windows and patio doors – Specifications/notes on the product and on liability (VHBH)" of the Quality Association for Locks and Fittings (Gütegemeinschaft Schlösser und Beschläge e. V.)

[guetegemeinschaft-schloss-beschlag.de/Pruefen-Zertifizieren/Richtlinien/VHBH](https://guetegemeinschaft-schloss-beschlag.de/Pruefen-Zertifizieren/Richtlinien/VHBH)







- Assembly instructions timber 2.0  
<https://link.si/td/hshz001/0624>
- Assembly instructions timber 4.0  
<https://link.si/td/hshz002/0624>

# Assembly instructions



DRIVE axxent LS timber elements

EN  
DE

## 1.6.1 Status LED battery pack

Symbol	Meaning
	LED off
	LED lights up
	LED flashes in 1 colour
	LED flashes alternately in 2 colours

## 1.6.2 Light ring operator push button

Symbol	Meaning
	Off
	Flashes
	Lights up

## 2 Safety

### 2.1 Designated use

DRIVE axxent LS is a drive for operating motorised lift and slide elements.

- The product is suitable for installation in lift and slide elements of the following product ranges:

Timber systems HS 2.0

Timber systems HS 4.0

- The product is suitable for installation in lift and slide elements with the opening type scheme A.
- Do not use the product:
  - in windows and patio doors that are intended as escape routes

- in fire-rated areas
- in conjunction with smoke extraction systems (SHEVS)
- in environments where the air contains aggressive components
- in outside areas

- Only use SIEGENIA power supplies that are both tested and certified in accordance with the EMC Directive. A change is not permissible.

EN

DE

### 2.2 Requirements for the target groups

#### 2.2.1 Producers of construction elements

We assume and require that producers of construction elements possess the following knowledge and skills:

- knowledge of the regulations concerning occupational safety and accident prevention
- comprehension of technical correlations based on the latest scientific and technological knowledge
- knowledge of professional work steps
- knowledge of the applicable standards and directives
- knowledge of applicable testing regulations
- knowledge and skills relating to the processing of the respective material (timber, PVC, aluminium)
- knowledge and skills relating to the professional use of tools, machines and systems for the production of window or door elements
- knowledge and skills relating to the professional fixing of technical elements
- knowledge of the functional testing and operation of window or door elements
- knowledge of the requirements of profile system providers

If the window or door elements are equipped with an electromechanical drive or a sensor, the following knowledge and skills are also presumed and required:

- knowledge and skills relating to the professional fabrication of electrical components
- knowledge and skills relating to the following work steps:
  - connecting electrical components
  - putting electrical components into operation
  - checking the function of electrical components
- knowledge of the following 5 safety rules:
  - disconnect
  - secure to prevent reconnection
  - ensure system is voltage-free
  - earth and short-circuit
  - cover or isolate proximate live parts

SIEGENIA provides training to enable you to acquire some of the knowledge and skills needed. Contact your SIEGENIA sales consultant if this is required.

### 2.2.2 Fitters and retrofitters

We assume and require that fitters and retrofitters possess the following knowledge and skills:

- knowledge of the regulations concerning occupational safety and accident prevention
- comprehension of technical correlations based on the latest scientific and technological knowledge
- knowledge of professional work steps
- knowledge of the applicable standards and directives
- knowledge and skills relating to the professional use of electrical and mechanical tools
- knowledge and skills relating to the professional fixing of technical elements
- knowledge and skills relating to the retrofitting of mechanical security technology on window or door elements

If the window or door elements are equipped with an electromechanical drive or a sensor, the following knowledge and skills are also presumed and required:

- knowledge and skills relating to the professional fabrication of electrical components
- knowledge and skills relating to the following work steps:
  - connecting electrical components
  - putting electrical components into operation
  - checking the function of electrical components
- knowledge of the following 5 safety rules:
  - disconnect
  - secure to prevent reconnection
  - ensure system is voltage-free
  - earth and short-circuit
  - cover or isolate proximate live parts

SIEGENIA provides training to enable you to acquire some of the knowledge and skills needed. Contact your SIEGENIA sales consultant if this is required.

### 2.3 Safety information

#### Risk of explosion if the battery pack handled incorrectly

Risk of explosion due to flammable liquids or gases escaping.

- Do not use faulty or defective battery packs.
- Discontinue using battery packs that show odour or heat development.
- Discontinue using battery packs that show deficient power output.
- Discontinue using battery packs that show discolourations or thermal deformations.
- Do not pierce, deform or dismantle the battery pack.

#### Danger due to sash movement despite shutting down the 230 V power supply

Even after shutting the 230 V power supply down the sliding element continues to move electrically because of the charged battery packs.

### 3 Product specifications

#### 3.1 Scope of delivery

The scope of delivery varies depending on the equipment

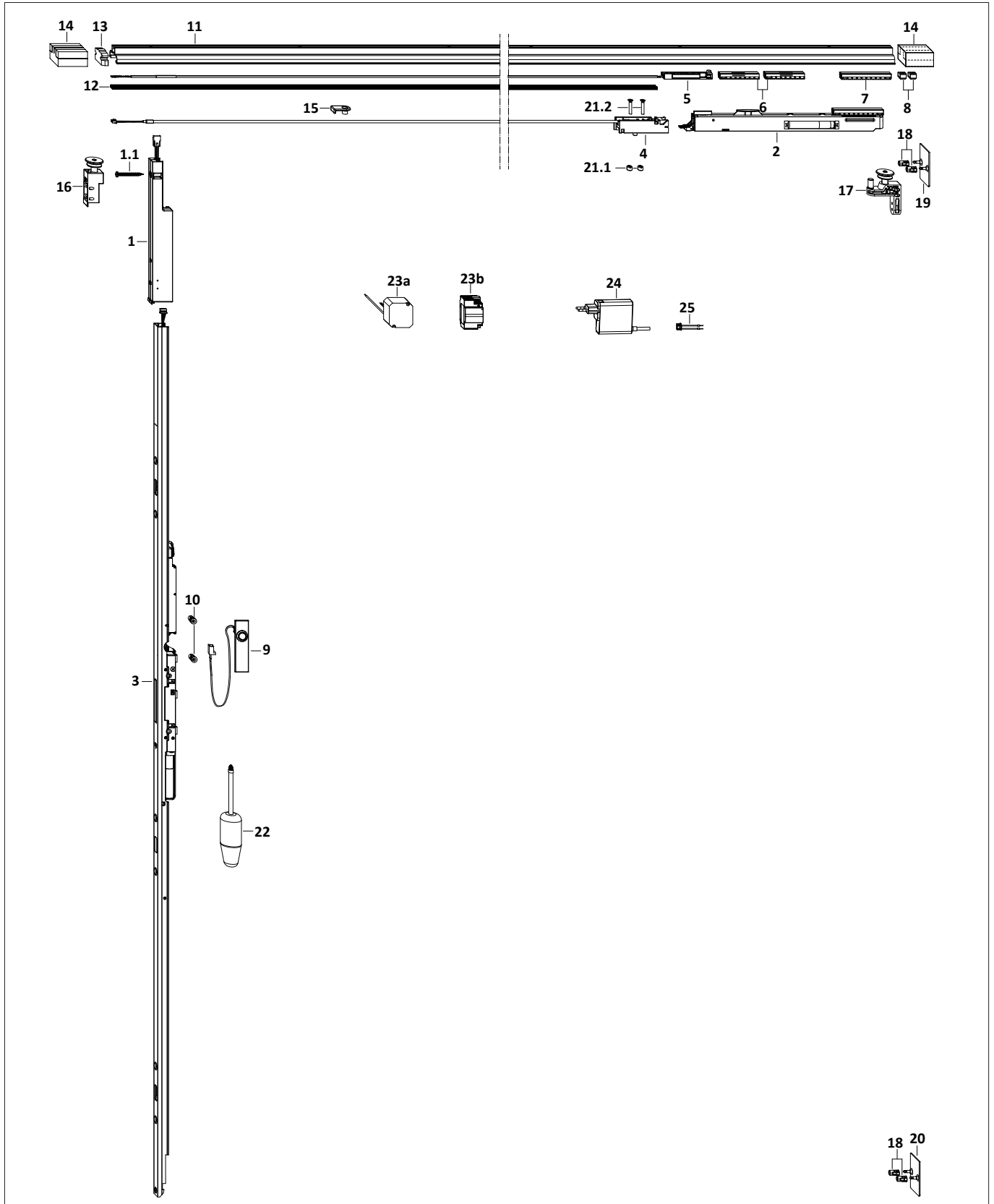

EN  
DE

# Assembly instructions

## DRIVE axxent LS timber elements

Item	Name	Quantity
1	Battery pack axxent LS	1
1.1	Screw PAN head PZ 4.0 x 35	1
2	Slide drive axxent LS	1
3	Lift drive axxent LS	1
4	Coupling shoe axxent LS timber	1
5	Charging contact axxent LS	1
6	Tooth segment/filling piece axxent LS	2
7	Tooth segment axxent LS	11 – 37
8	Clamping piece SC axxent LS	2
9	Operator push button axxent LS	1
10	Socket operator push button axxent LS	2
11	Guiding rail SC002 axxent LS	1
12	Cover rail axxent LS	1
13	Filling piece SC groove axxent LS	1
14	Sealing piece SC002 axxent LS	2
15	Cable hold-down clamp axxent LS	2 – 14
16	Guide o. v. axxent LS	1
17	Catch axxent LS timber	1
18	Socket	4
19	Cover top	1
20	Cover bottom	1
21.1	Screw-in sleeve M5 (only for profile system slim)	2
21.2	Countersunk screw M5 (only for profile system slim)	2
22	Emergency operating key	1
23a	Power supply UP 36W	1
23b	Power supply rail nut axxent LS	
<b>Accessories</b>		
24	Power supply plug axxent LS	1
25	Charge adapter battery pack axxent LS	1

EN

DE

### 3.2 Label

The labels serve to identify the product.  
The labels can be found on the battery pack, the gear and the slide drive.

1	Label battery pack
2	Label gear
3	Label slide drive
4	QR code with customer order number



EN  
DE

### 3.3 Operating and display elements

#### 3.3.1 Status indicator and menu button on the battery pack axxent LS

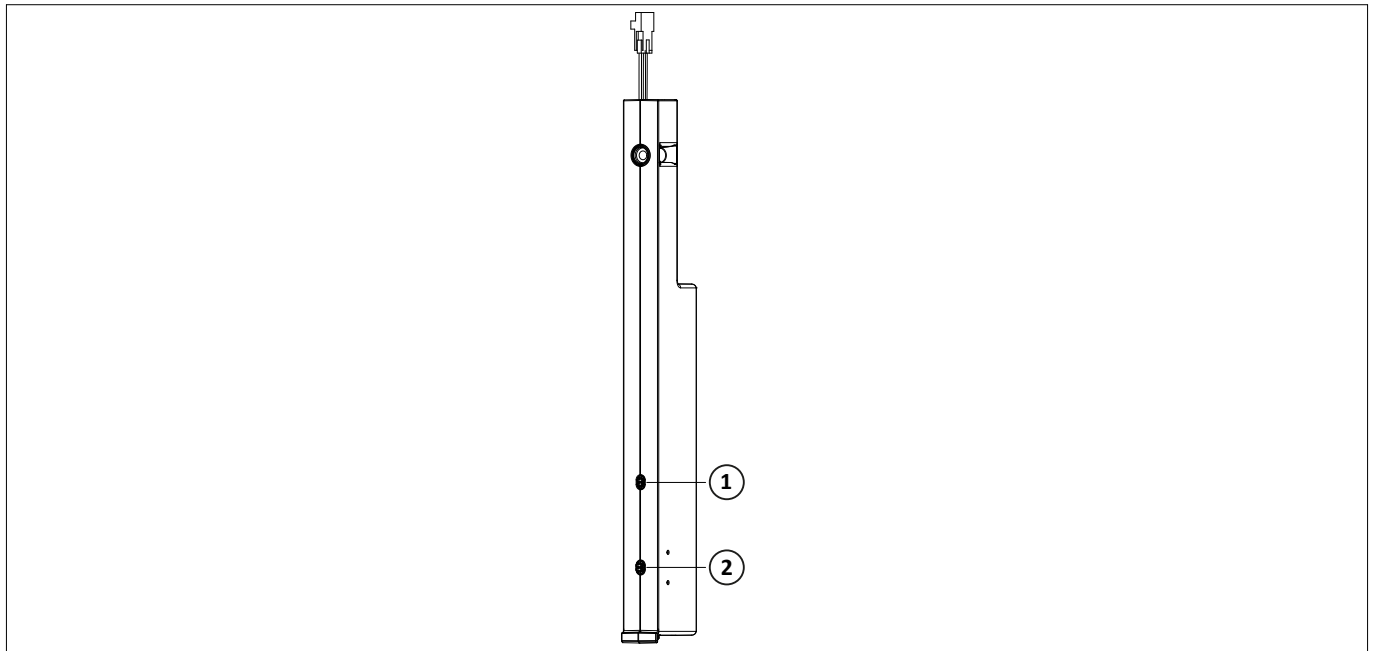

1	Status indicator (multi-colour LED)	<ul style="list-style-type: none"> <li>• Function control</li> <li>• Display of the menu</li> </ul>
2	Menu button (multi-colour LED)	<ul style="list-style-type: none"> <li>• Waking the battery pack</li> <li>• Change of the menu items within the menu level 1 and 2</li> </ul>

Button pressed	Timespan	
Short press	0 – 1 second	
Long press	3 seconds	
Constant press	8 seconds	

### 3.3.2 Operator push button axxent LS

1	Operating button		<ul style="list-style-type: none"> <li>• Short press (0 – 1 second)</li> <li>• Long press (1 – 3 seconds)</li> <li>• Constant press (&gt; 3 seconds)</li> </ul>
2	Light ring		<ul style="list-style-type: none"> <li>• Sash lowered and locked</li> <li>• Sash opened and stopped</li> </ul>
			<ul style="list-style-type: none"> <li>• Sash moves</li> <li>• Sash in locking position, but not lowered</li> </ul>
			<ul style="list-style-type: none"> <li>• Sash raises</li> <li>• Sash lowers</li> </ul>

EN

DE

## 3.4 Operation

### 3.4.1 Functions of the operator push button

#### Pairing mode

- For connecting the lift drive and slide drive to the battery pack.
- For controlling the lift drive without slide drive present.
- The long press starts the pairing process.
- The battery pack switches itself off after 10 minutes:
  - as long as a mains supply is not connected;
  - when a sash is standing open;
  - This way the battery pack is protected against discharge.

# Assembly instructions

## DRIVE axxent LS timber elements

### Processor mode

- For performing the reference run and teach-in run.
- The short press starts the reference run.
- Acoustic signals sound during the short press of the operator push button.
- The long pres starts the teach-in run.
- When retracting into the charging contact (start of the charging) and when extending from the charging contact (end of the charging) an acoustic signal sounds at the mains supply connected.
- The battery pack switches itself off after 30 minutes:
  - as long as a mains supply is not connected;
  - when a sash is standing open;
  - This way the battery pack is protected against discharge.

EN

DE

### Operator mode

- Full range of functions for the operation at the end customer's location.
- Acoustic signals no longer sound during the short press of the operator push button.
- The intermediate position is reached using the long press.
- The long press is confirmed with an acoustic signal.

### 3.4.2 Functions of the battery pack

Depending on the mode, the battery pack will switch of automatically. An ascending and descending tone sequence is emitted.

**Prerequisite:** the sliding sash is not in the charging contacts (if voltage is present, then the battery pack does not switch itself off automatically).



- in the pairing mode after 10 minutes (after the last action; this includes pressing on the menu button or the operator push button)
- in the processor mode after 30 minutes (after the last action; this includes pressing on the menu button or the operator push button)

- in the operator mode no time-dependent shutdown occurs
- in all modes the option to switch off manually via the menu button

The battery pack is woken by pressing on the menu button. An ascending tone sequence is emitted and the LEDs on the status indicator and on the menu button light up. The LEDs switch off automatically after 2 minutes.

### 3.4.3 Querying the charge status of the battery pack

- Short press on the menu button: > the status LED and the menu button light up
- Short press on the menu button
- The charge status is displayed for 10 seconds on the status-LED
- **The menu button LED flashes white while the status LED displays the charge status**

Charge status	Display status-LED	
100 % – 40 %	The status LED lights up green	
39 % – 20 %	The status LED lights up yellow	
19 % – 0 %	The status LED lights up red	

EN

DE

### 3.4.4 Status monitoring

The status monitoring is permanently carried out. This means that the product is always in active operating status. This safety function means that there is no standby status for the present device. The status monitoring detects if the sliding sash is opened from the locked status without drive activity. This corresponds to an unauthorised opening, for which an alarm tone is emitted.

- **Prerequisite:** The slide drive is in the processor mode or in the operator mode
- When the fully paired sliding sash is manually moved from the locked position, an alarm tone is emitted for 1 minute
- Turning the emergency operating key also triggers the alarm tone

Deactivate the alarm tone:

- In the processor mode the alarm tone is cancelled by short press on the operator push button
- In the operator mode the alarm tone cannot be cancelled directly; the alarm tone is emitted for 1 minute

# Assembly instructions

## DRIVE axxent LS timber elements

### 3.4.5 Jam protection

- As soon as the path of the sliding sash becomes blocked, (e.g. due to an obstacle or because it is stuck), it stops
- 3 short acoustic warning signals sound
- The operator push button LED changes for a few seconds from continuous lighting to flashing
- The sliding sash travels 100 mm in the opposite direction and then comes to a final stop

## 3.5 Menu

### 3.5.1 Menu level principle

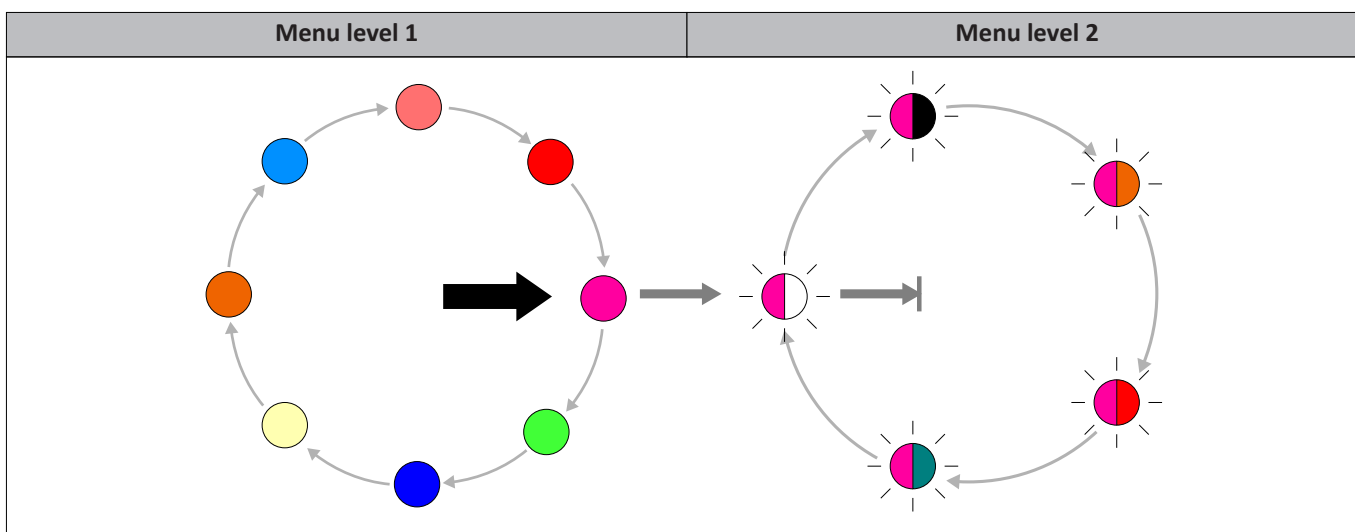

Button pressed	Description
• Every press of a button is confirmed by an acoustic signal.	
Short press	The battery pack is woken.
➡ constant press (selection)	Select menu level 1. The selection always starts with a magenta menu item.
➡ long press	Change the desired menu item to menu level 2.
↪ short press	Change the menu items within the menu level.
➡ long press (confirmation)	Save or execute the desired menu item.
Leaving a menu level without activating a setting:	
<ul style="list-style-type: none"> <li>• Wait time 30 seconds</li> <li>• Do not press the menu button again</li> </ul>	

3.5.2 Menu selection

LED menu level 1	LED menu level 2	Description of menu level 2
<b>Volume of the information tones</b>		
		<b>100 % (default setting)</b>
		75 %
		50 %
		25 %
		OFF
<b>LED brightness of the operator push button</b>		
		<b>100 % (default setting)</b>
		75 %
		50 %
		25 %
		OFF
<b>This function is not allocated.</b>		







EN  
DE

# Assembly instructions

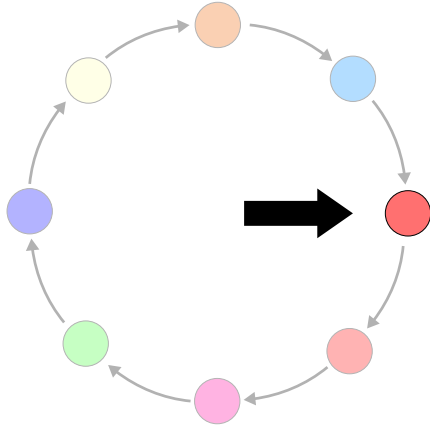
DRIVE axxent LS timber elements

EN  
DE

LED menu level 1	LED menu level 2	Description of menu level 2
<b>Parallel lift and slide</b>		
		<b>ON (default setting)</b>
		OFF
<b>Silent mode (softer and slower)</b>		
		ON
		<b>OFF (default setting)</b>
<b>Device services</b>		
		Restart the device
		Reset all menu items to default setting
		Deactivate battery pack
		Save intermediate position <ul style="list-style-type: none"> <li>• Move sash to any position</li> <li>• Select menu item and save position</li> </ul>
		Activate reference, measuring and teach-in run
		Activate fabricator mode

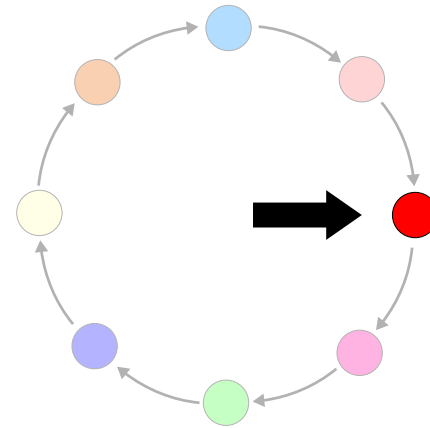
LED menu level 1	LED menu level 2	Description of menu level 2
<p>The following menu levels can only be selected under one of the following conditions (in processor mode for 5 hours, in operator mode for 30 minutes):</p> <ul style="list-style-type: none"> <li>• Disconnect the slide drive from the battery pack, or</li> <li>• the element must be in the closed and locked state for &gt; 1 minute. Then disconnect the power supply (230 V) for &gt; 10 seconds.</li> </ul>		
<b>System services</b>		
		Couple devices
		Disconnect devices
		This function is not allocated.
		Resetting to the factory setting
		This function is not allocated.
		This function is not allocated.
<b>This function is not allocated.</b>		
		

EN  
DE

# Assembly instructions

DRIVE axxent LS timber elements

## 3.6 Processing dimensions

### 3.6.1 Hardware size range

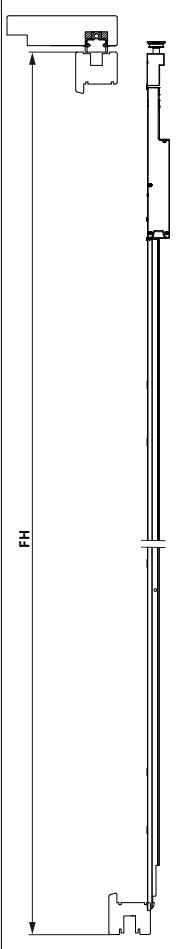
Size ranges sash height (FH) with standard gear					
	Gear size	with running rail 0 mm: sash height (mm)	with running rail 5 mm: sash height (mm)	with running rail 15 mm: sash height (mm)	Sash width (mm)
	Size 1	1950 – 2145	1950 – 2150	1950 – 2160	min. 850
	Size 2	2146 – 2345	2151 – 2350	2161 – 2360	
	Size 3	2346 – 2545	2351 – 2550	2361 – 2560	
	Size 4	2546 – 2745	2551 – 2750	2561 – 2760	
	Size 5	2746 – 2945	2751 – 2950	2761 – 2960	
	Size 6	2946 – 3145	2951 – 3150	2961 – 3160	

EN  
DE

3.6.2 Drilling dimensions for the operator push button

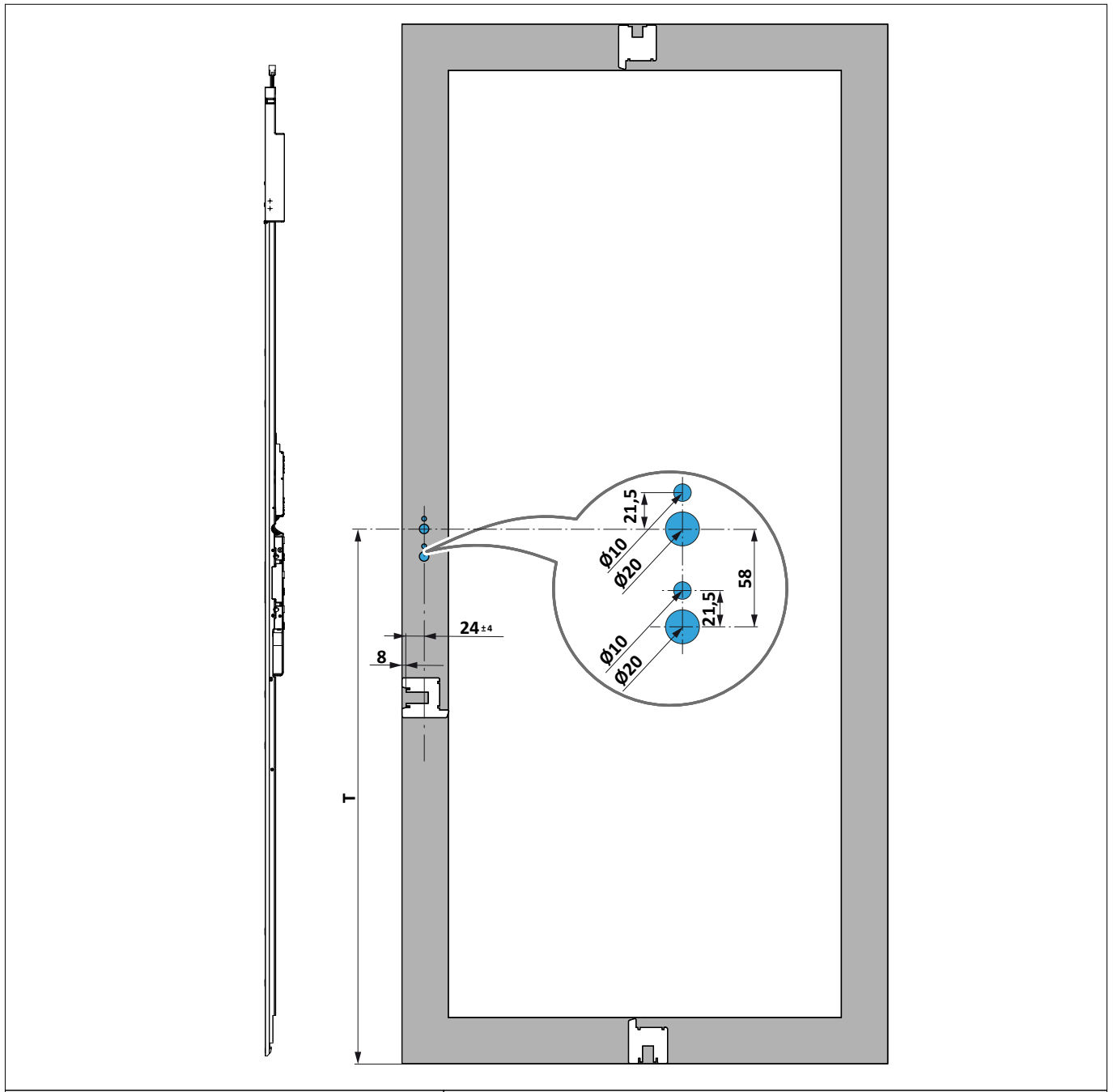

T Position of the button hole  
Dimensions in mm after surface treatment

Running rail (mm)	T (mm)
0	1148
5	1153
15	1163

EN  
DE

# Assembly instructions

## DRIVE axxent LS timber elements

### 3.6.3 Milling dimensions for the battery pack and the lift drive

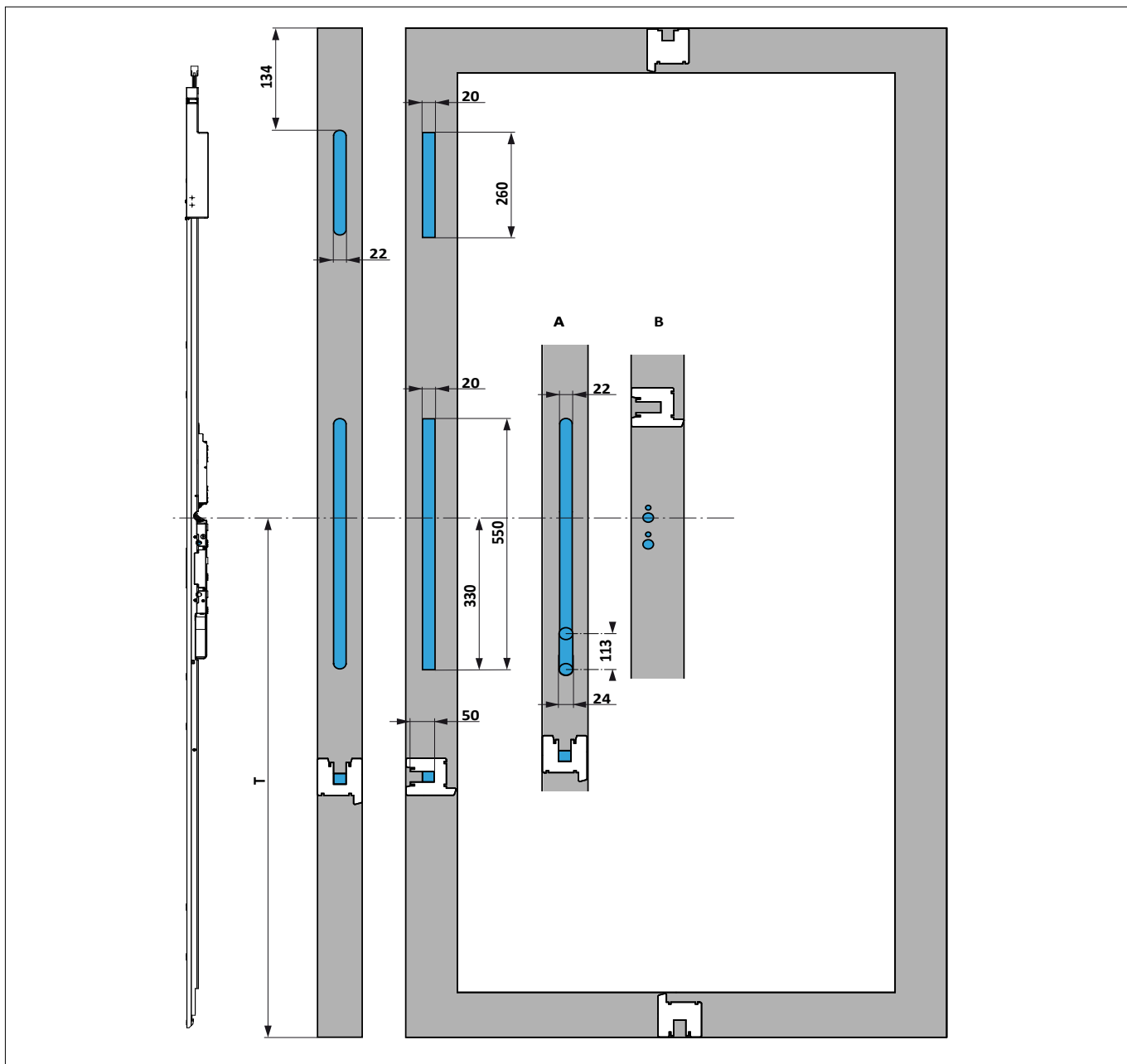

A	Detail milling gear box/gear motor
B	Detail button hole
T	Position of the button hole
Dimensions in mm after surface treatment	

Running rail (mm)	T (mm)
0	1148
5	1153
15	1163

### 3.6.4 Drilling dimensions for the cable connection

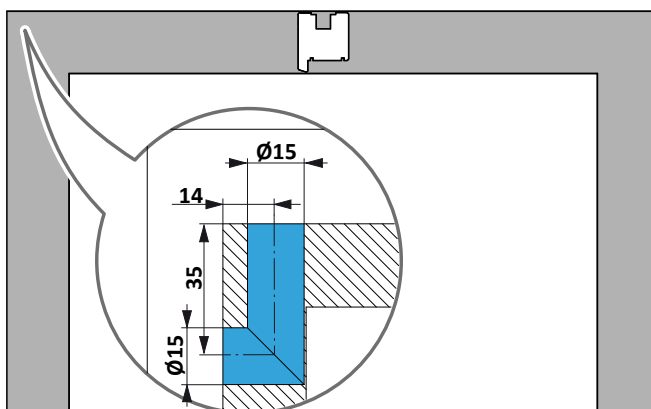

Dimensions in mm after surface treatment

EN

DE

### 3.6.5 Milling dimension for slide drive

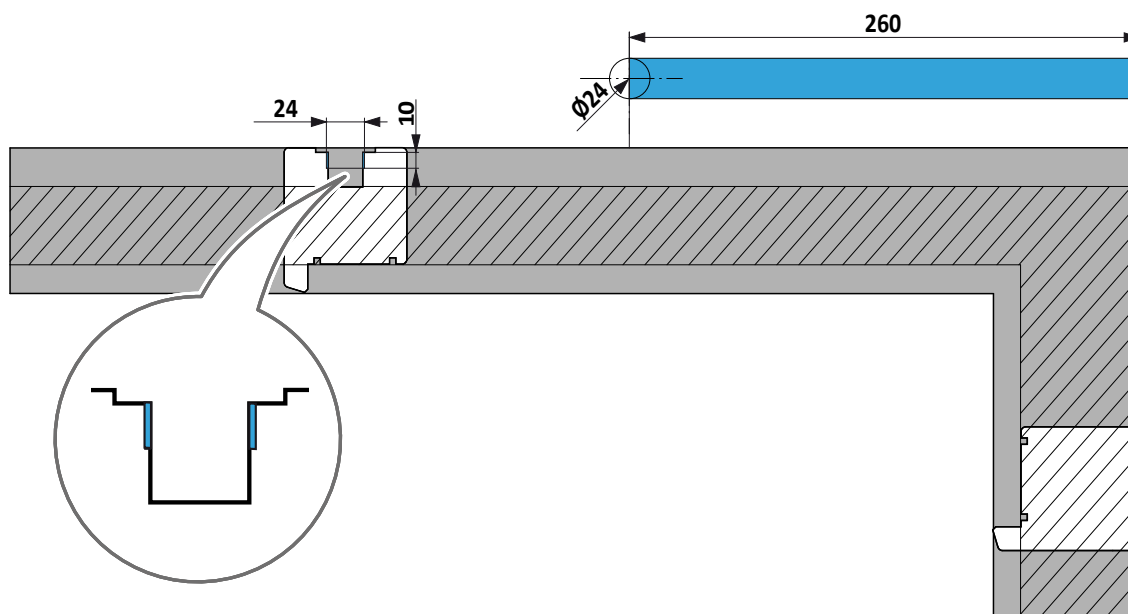

Dimensions in mm after surface treatment

# Assembly instructions

DRIVE axxent LS timber elements

## 3.6.6 Milling dimensions for the catch

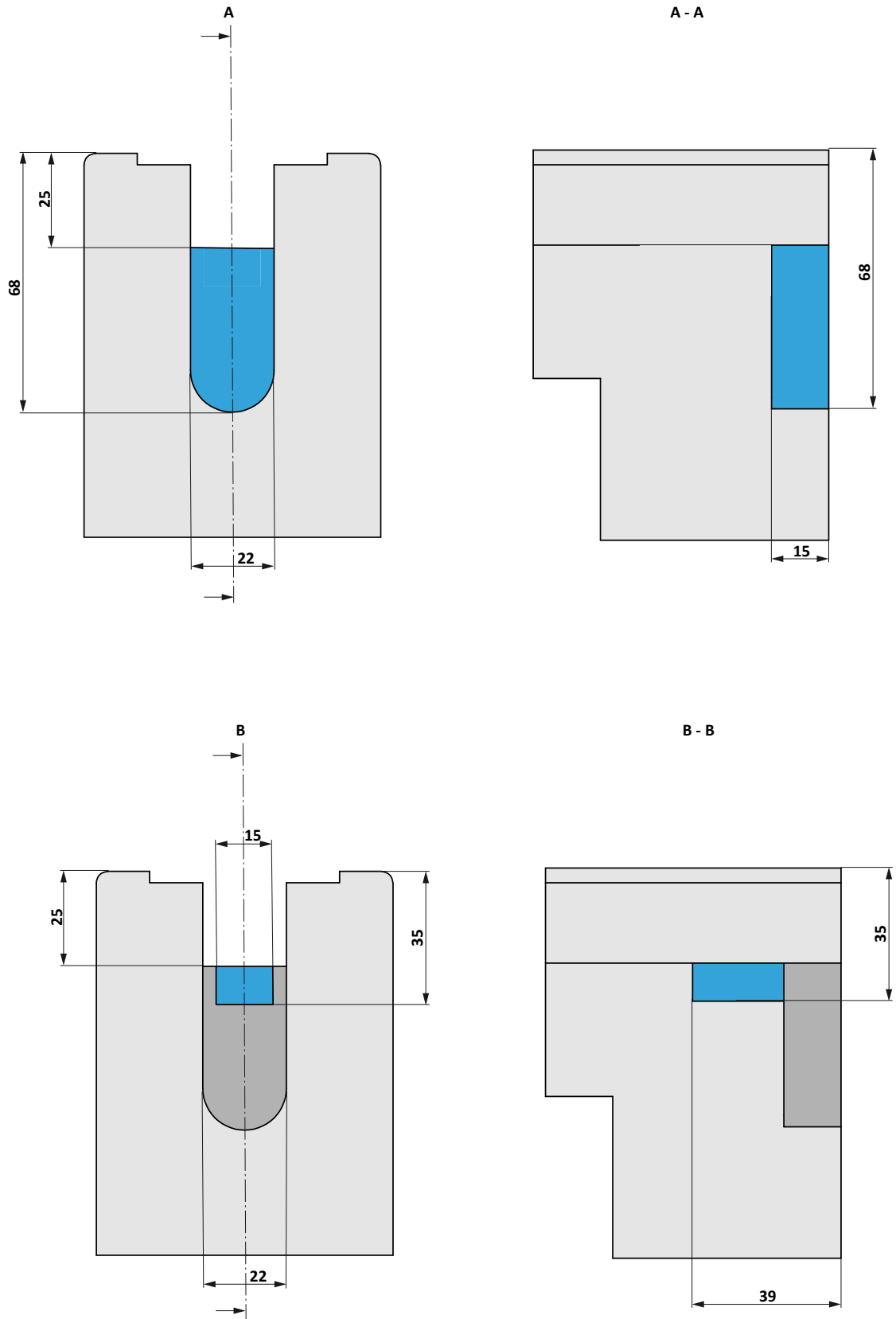

Dimensions in mm after surface treatment

3.6.7 Drilling dimensions for the CUBE sockets

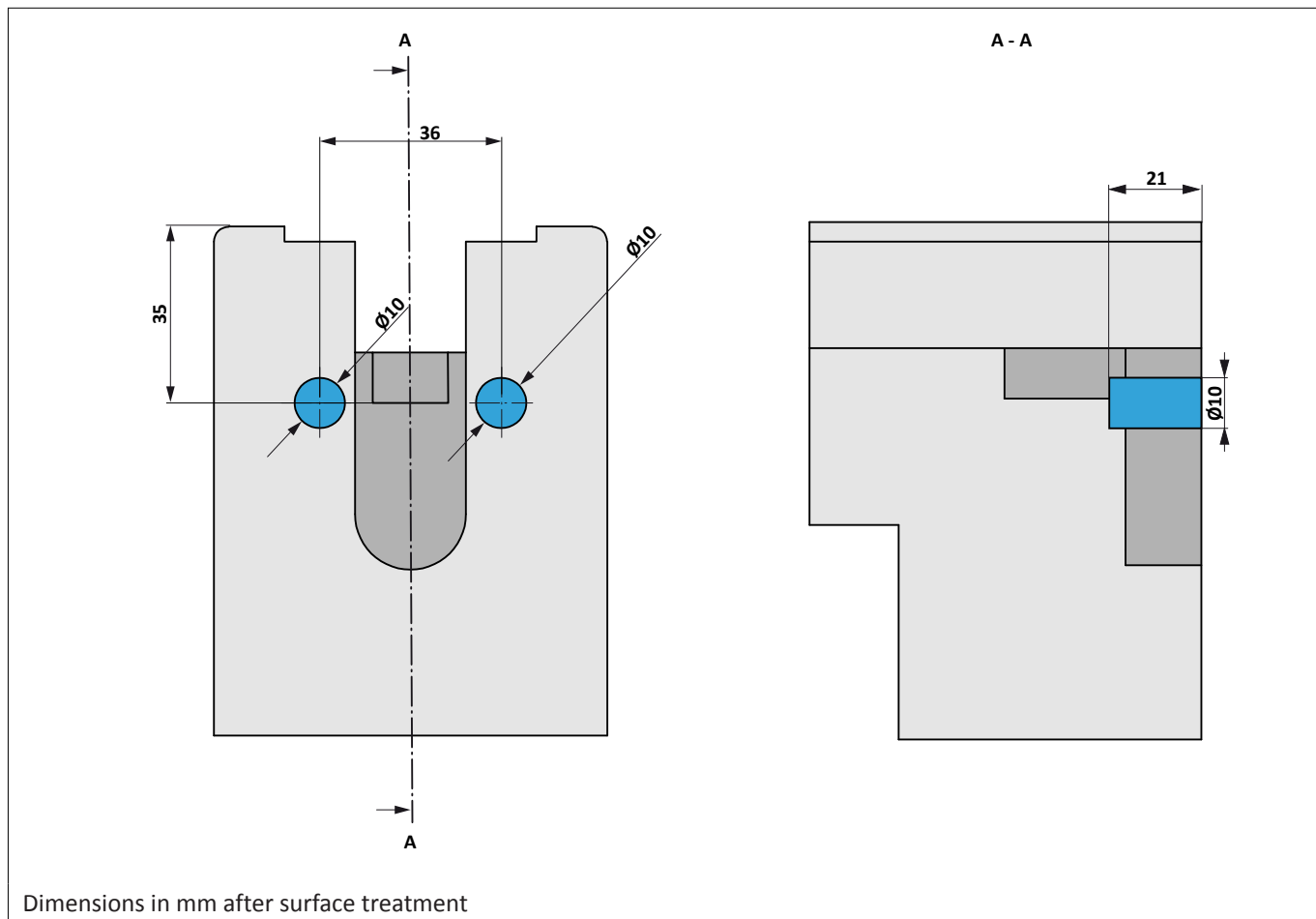

EN  
DE

# Assembly instructions

## DRIVE axxent LS timber elements

EN  
DE

### 3.6.8 Drilling dimensions for the coupling shoe

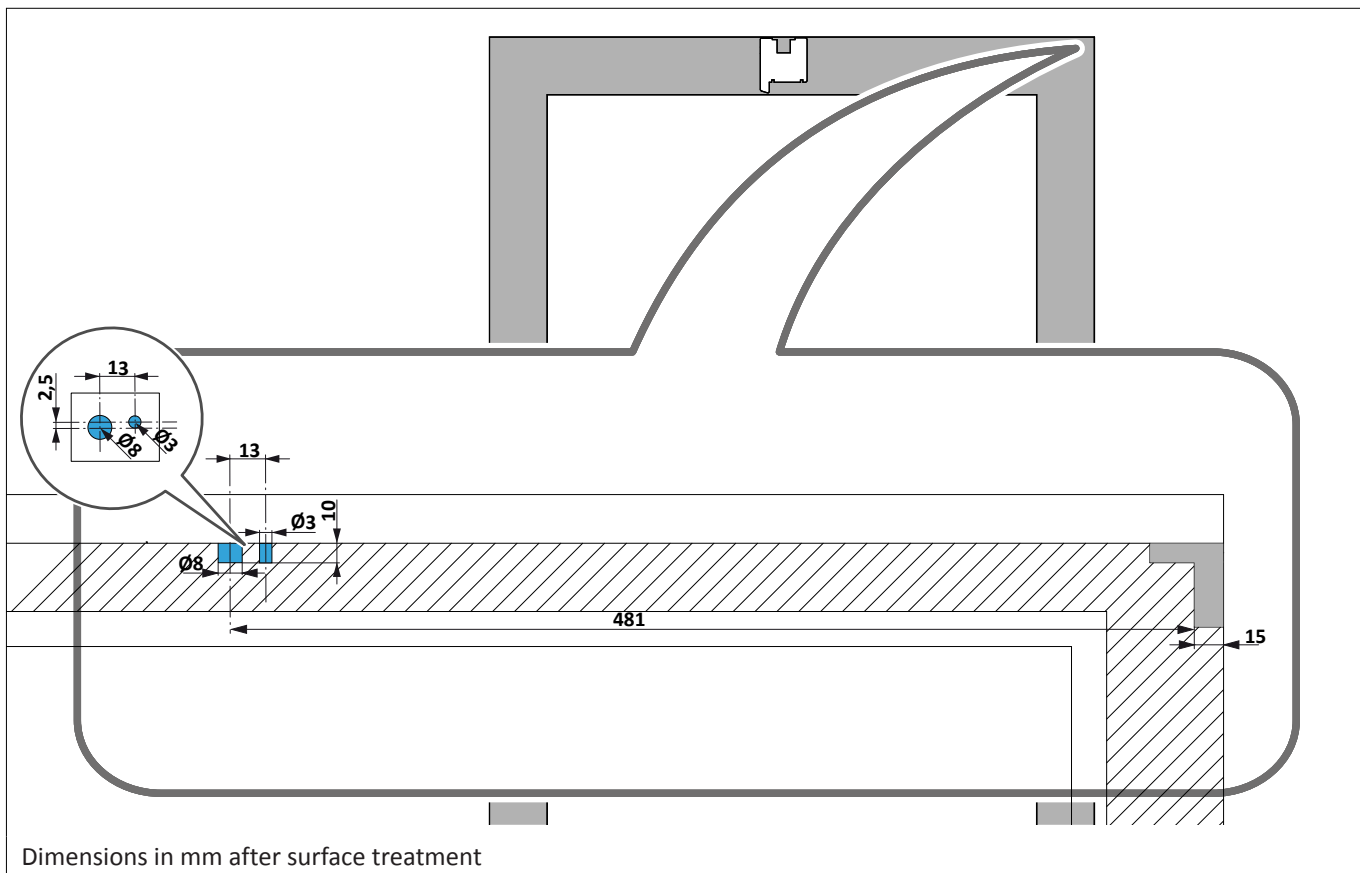

### 3.6.9 Drilling dimension for the charging cable

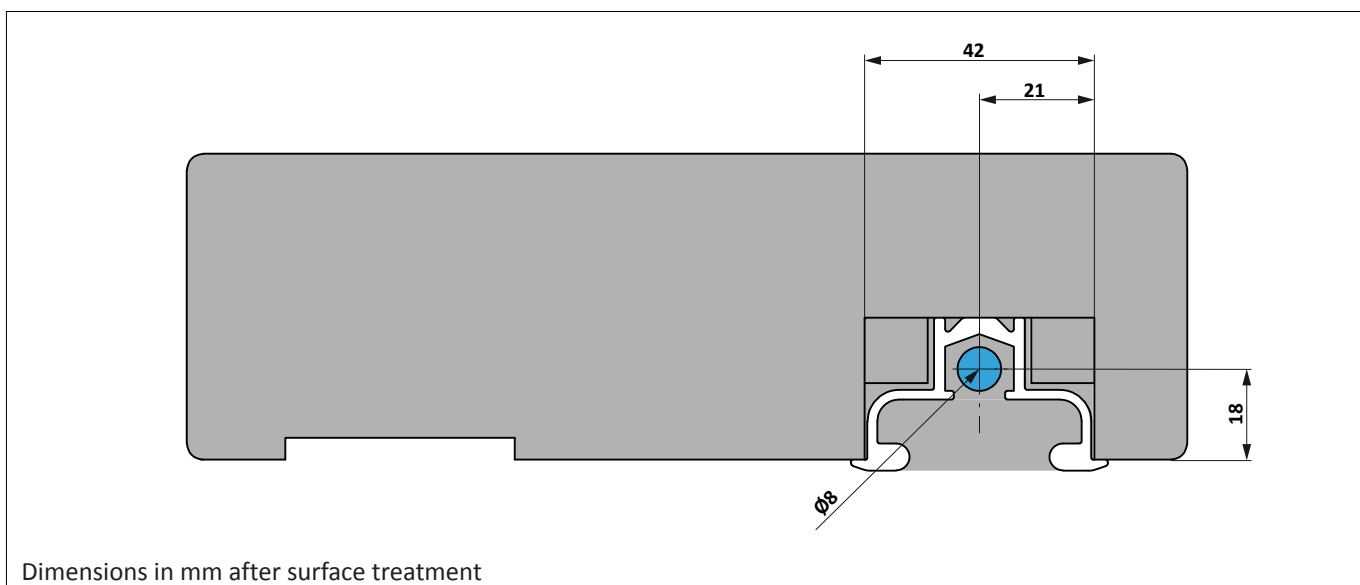

### 3.7 Electrical connection

#### 3.7.1 Connecting the lift and slide element to the electricity grid

- **CONNECT THE DRIVE AXXENT LS TO 24 VOLTS ONLY**
- Do not route cable with data lines and not on cable racks, in ceiling voids and in shared cable ducts in public buildings / high-rise buildings
- Extension of the line of the charging contact axxent LS, supplied, only feasible with a line with wire cross-section of min. 1.5 mm<sup>2</sup>
- Total line length for the top hat rail power supply: 100 m
- Total line length for the built-in power supply: 50 m
- Minimum installation depth of the installation socket for the built-in power supply: 60 mm

EN

DE

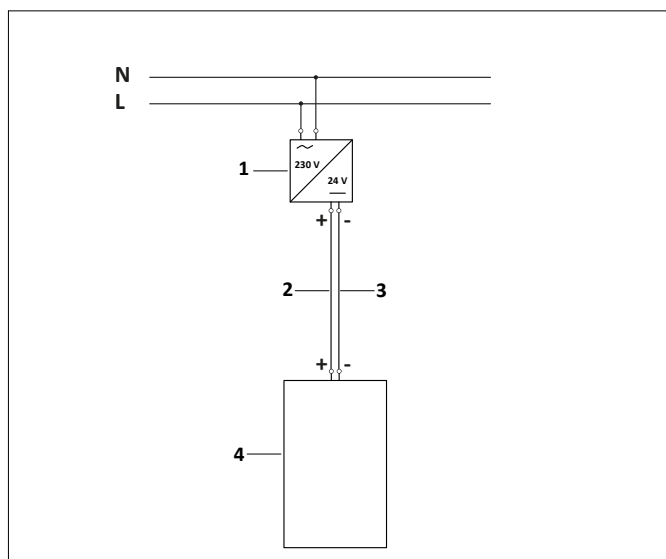

1	Power supply
2	+ 24 V DC (red)
3	- GND (black)
4	DRIVE axxent LS

# Assembly instructions

## DRIVE axxent LS timber elements

### 3.7.2 Function control of the charging contact

#### Requirements:

- The processor mode (cf. chapter "How it works") is active.
- The lift and slide element is connected to a power supply.

1. **TIP:** Move the sliding sash in and out of the charging position by hand.

→ An acoustic signal sounds when retracting from the sliding sash.

The status LED lights up magenta for 2 seconds.

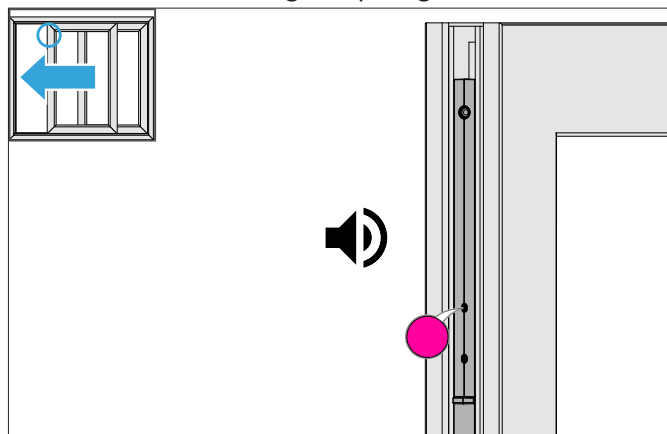

→ An acoustic signal sounds when extending from the sliding sash.

The status LED lights up red for 2 seconds.

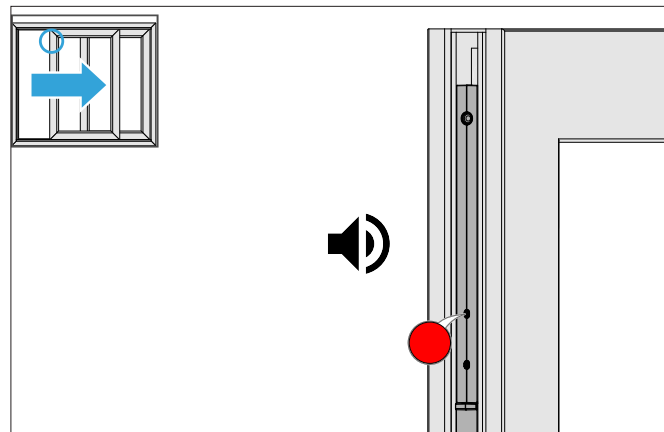

→ The charging contact is in the correct position.

→ The power connection is made correctly.

EN  
DE

### 3.7.3 Charging a single battery pack

For various reasons it may be necessary to charge the battery pack before further use. One reason is:

- The charge capacity of the battery pack is not sufficient for the commissioning (the status LED lights up yellow or red).

To charge the single battery pack use the power pack corrector PZMR0050 and the charge adapter PZMR0070.

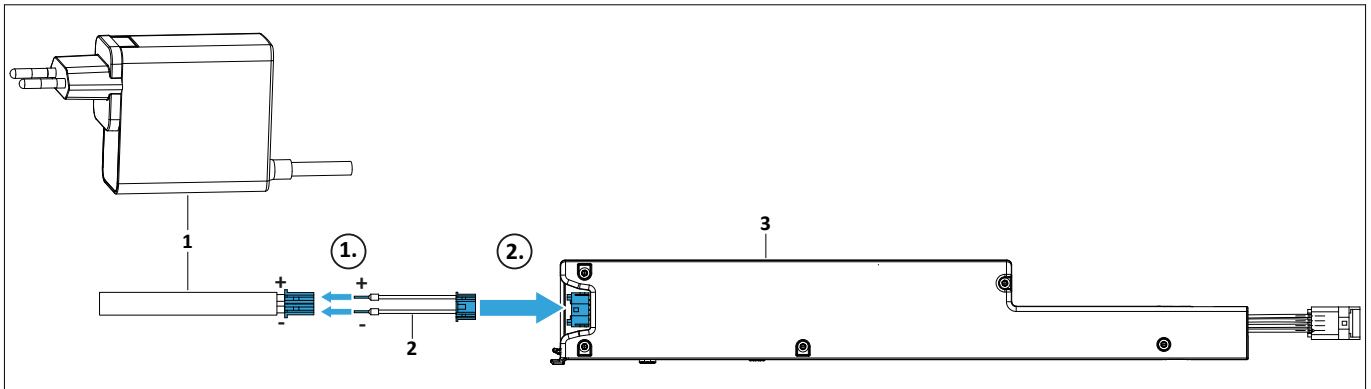

Item	Name
1	Power supply plug axxent LS
2	Charge adapter
3	Battery pack
+	24 V DC (red)
-	GND (black)

EN

DE

# Assembly instructions

## DRIVE axxent LS timber elements

### 3.7.4 Use of the power pack corrector

The power pack corrector PZMR0050 is intended for provisional and transitional power supply only.



### 3.8 Technical specifications







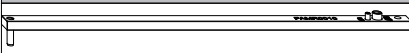
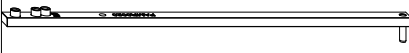
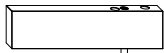
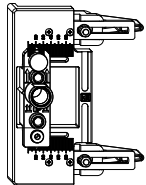

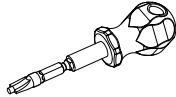
Technical specifications DRIVE axxent LS	
Supply voltage	24 V DC
Operating current standby / standby	non existent
Reverse polarity protection	existent
Operating temperature range	-20 °C to +60 °C
Permissible air humidity (non condensing)	20 % – 80 %
Protection type	IP 20
Protection class	0, 1, 2, 3
Corrosion class (in accordance with DIN EN 1670)	1
Durability class (in accordance with EN 13126-16)	H3, 20000 cycles
Maximum displacement force	60 N
Opening speed (dynamic impact forces in accordance with DIN EN 16005)	< 250 kg: 140 mm/sec. 251 – 400 kg: 110 mm/sec.

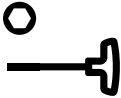
Technical specifications battery pack	
Authorisation number of the lithium cells	UN 38.3
Nominal capacity	3 Ah
Energy	32.4 Wh
Maximum charging current	1.1 A
Charging temperature range	0 °C to + 60 °C
Weight	220 g
Recommended temperature range storage	0 °C to + 20 °C

## 4 Installation

### 4.1 Tools and work equipment

Special tool	Intended use	Mat. No.
 Jig coupling shoe timber	Screws and fixing pin coupling shoe	PAMR0010-...
 Jig coupling shoe timber slim	Screw-in sleeves M5 and fixing pin coupling shoe only for profile system slim	PAMR0020-...
 Insertion aid coupling shoe	Screw-in sleeves M5 only for profile system slim	PAMR0030-...
 Jig button panel emergency release	Button panel emergency release	PAMR0210-...
 Jig connection line coupling shoe	Through hole connection line coupling shoe	PAMR0200-...
 Jig sockets CUBE cover	Sockets CUBE cover	PABB0490-...
 Screwdriver for screw-in sleeve M5	Insertion of screw-in sleeve for profile system slim	PABB0740-...

Tooling	Intended use
 Hexagon wrench with ball head 4 mm	Fixing the clamping pieces
 Slotted screwdriver 7 mm	Tensioning the filling pieces
 Drill Ø 3 mm	Hole fixing screw coupling shoe
 Ø 4 mm drill	Holes for gear
 Ø 8 mm drill	Hole fixing pin coupling shoe
 Ø 10 mm drill	Holes sockets buttons
 Ø 15 mm drill	Through hole line coupling shoe
 Hole saw Ø 20 mm	Emergency release button

# Assembly instructions

## DRIVE axxent LS timber elements

EN

DE

### 4.2 Preparing for installation

1. Mill the sliding sash and frame according to the machining dimensions (see page 20).
2. Remove any splinters from routed pockets.
3. Before installing the product, check the dimensional accuracy of the sliding sash and the frame. Do not install the product in the event of warping or damage.  
Dimensional tolerances for frames and sashes:  
 $\pm 1$  mm
4. Check the product for damage. Do not install the product if it is bent or damaged.
5. Route the power supply cable to the drives without kinks and without crushing.

### 4.3 Assembling the frame parts

#### 4.3.1 Overview of the assembly sequence

##### Proper adjustment of the guiding rail in the frame

- Position the guiding rail correctly
- All assembly steps are shown on an element DIN LH
- Carry out all assembly steps mirrored in case of assembly DIN RH

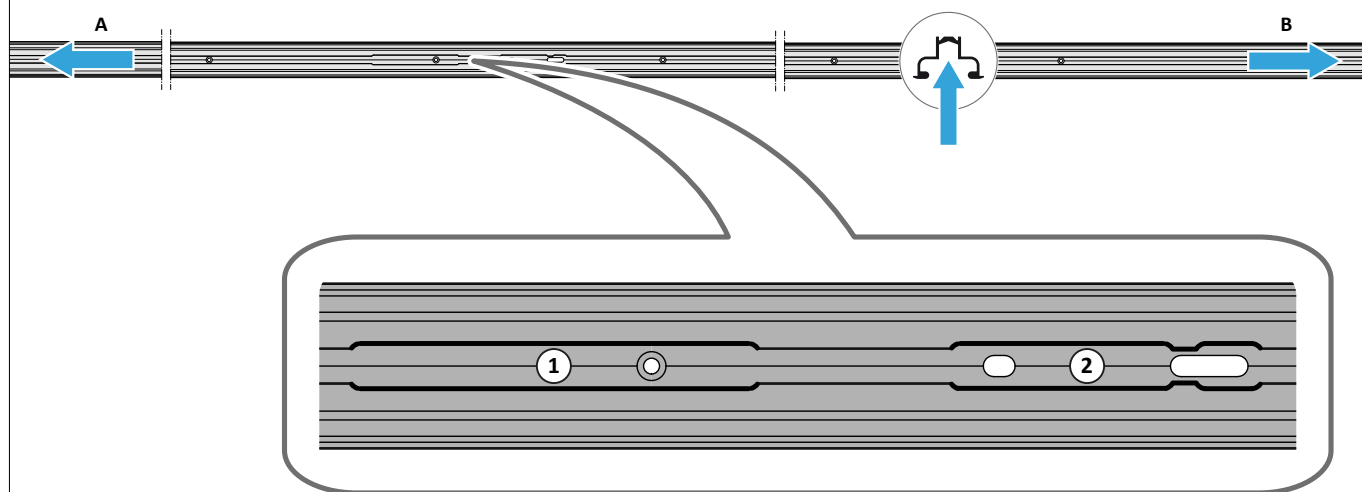

A	Locking side
B	Fixed sash side
1	Assembly opening clamping pieces, slide unit, tooth segments
2	Assembly opening charging contact

Properly pushing the components into the assembly openings of the guiding rail

Pushing the components into assembly opening 1:

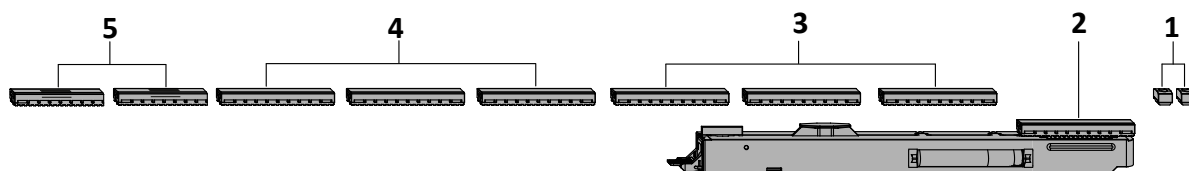
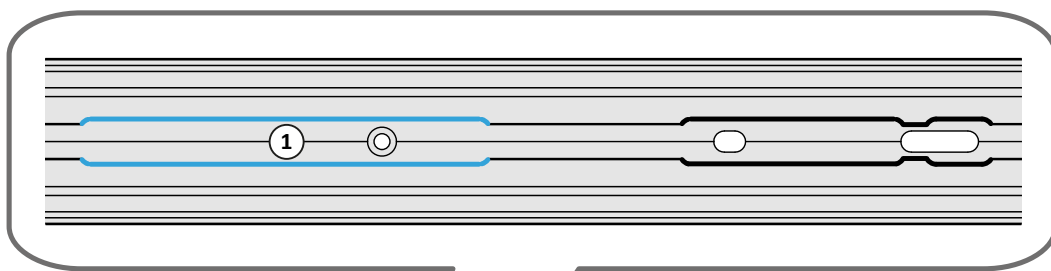

Pushing the component into assembly opening 2:

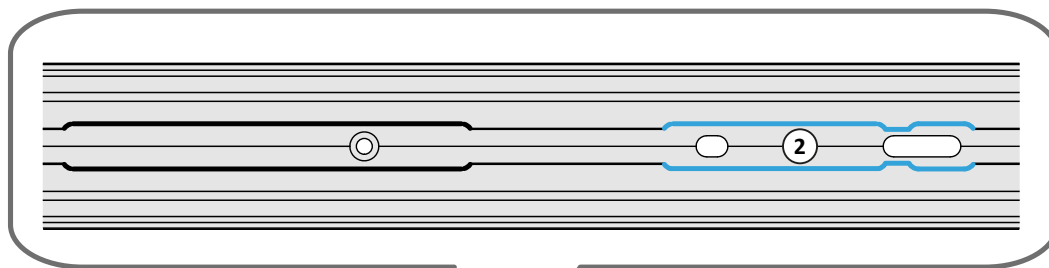

1 - 6

Assembly sequence of the components

# Assembly instructions

DRIVE axxent LS timber elements

## 4.3.2 Assembly of frame parts in the guiding rail

1. Guide the cable from the charging contact through the sealing piece SC002.  
Pull excess cable outward through the sealing piece SC002.

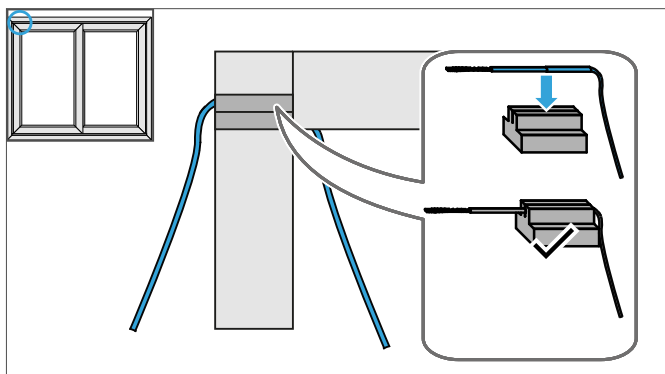

2. Insert the front guide into the locking side of the guiding rail.

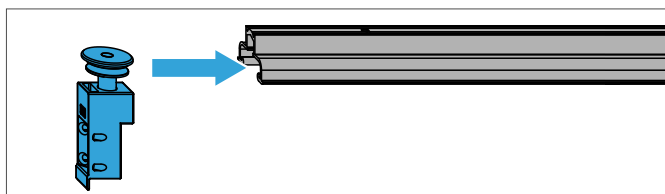

3. Insert the catch into the guiding rail from the fixed sash side.

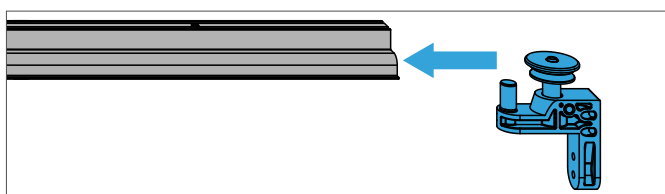

4. Position the guiding rail in the frame correctly and screw firmly.

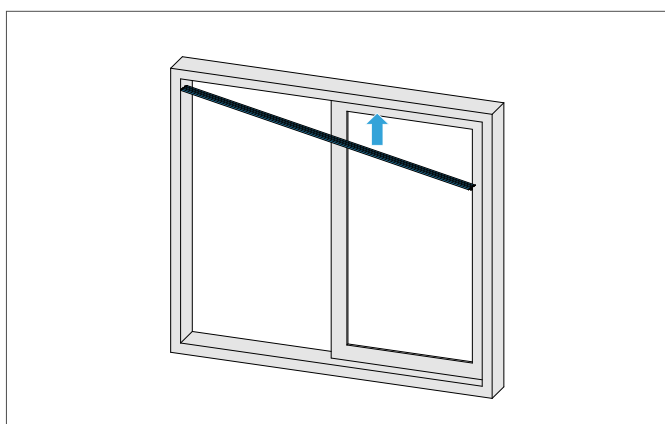

5. Insert the clamping pieces into the assembly opening 1 and push in the direction of the fixed sash side.

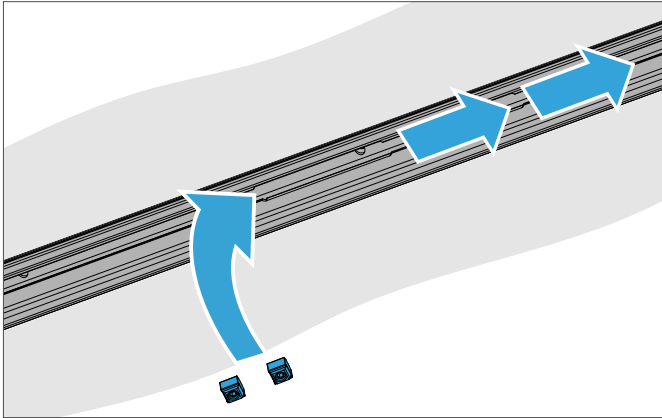

6. Fix the outer clamping piece at the end of the guiding rail.

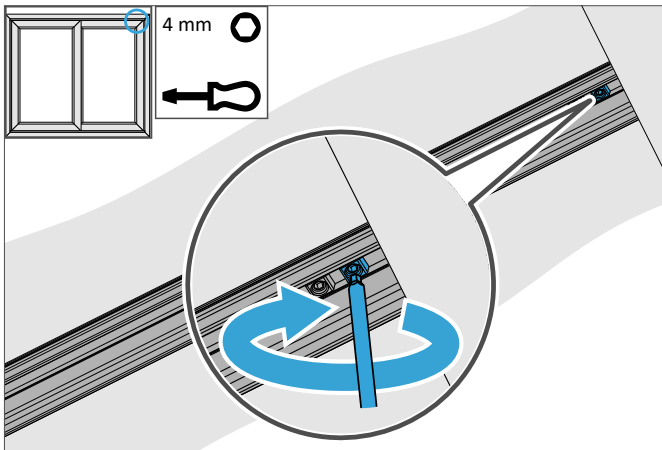

7. (1) Insert the slide drive into the assembly opening 1 and push a little in the direction of the fixed sash side. (2) Then lay 3 tooth segments in the assembly opening 1 and push a little in the direction of the fixed sash side.

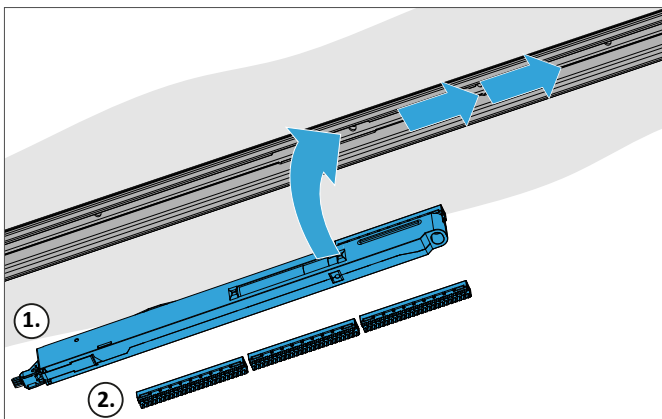

8. Push the 3 tooth segments over the guide of the slide drive. Grasp the entire unit on the tooth segments and push in the direction of the fixed sash side.

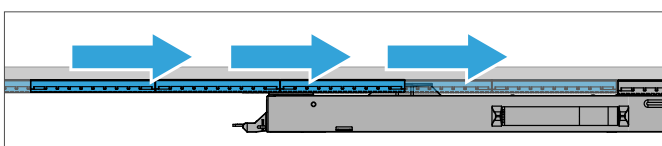

## Assembly instructions

### DRIVE axxent LS timber elements

9. Push the entire unit on the clamping pieces. The tooth segments must lie in place on the clamping pieces.

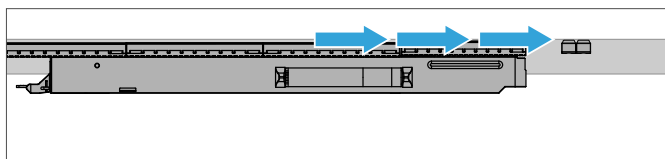

10. Lay the remaining tooth segments one after another in the assembly opening 1 and push in the direction of the fixed sash side.

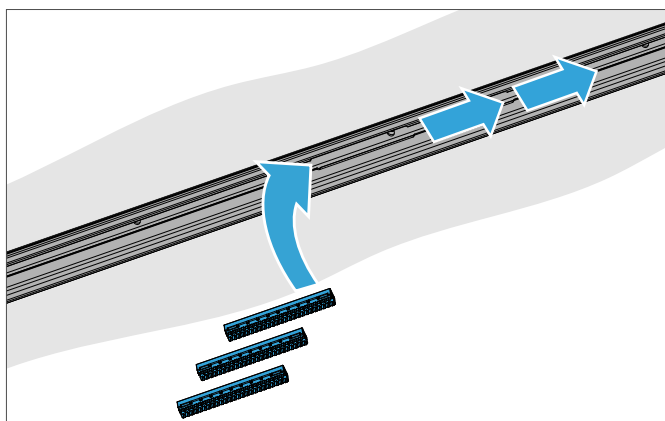

11. Lay the two marked filling pieces one after another in the assembly opening 1 and push in the direction of the fixed sash side.

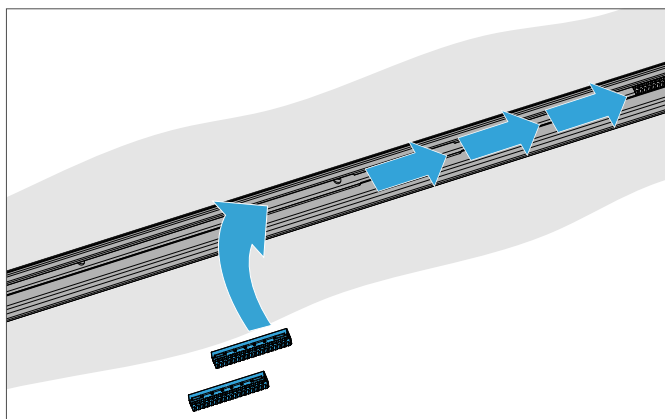

12. Lay the charging contact in the assembly opening 2. Route the connecting cable of the charging contact to the installation reserve pulled into the guiding rail.

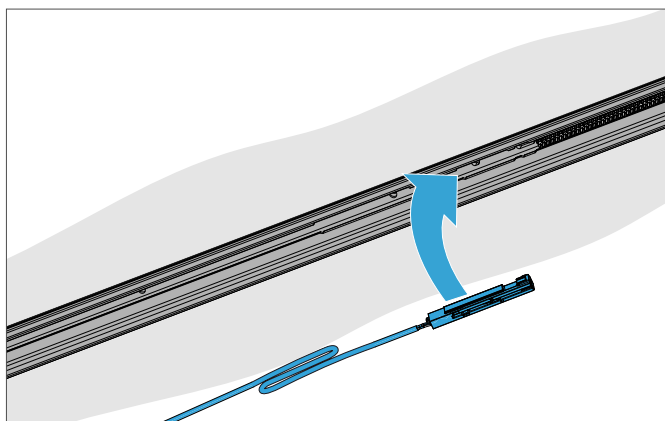

13. To fix the charging contact, push in the direction of the locking side.

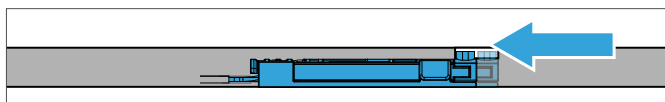

14. Pull excess cable outward through the sealing piece SC002.

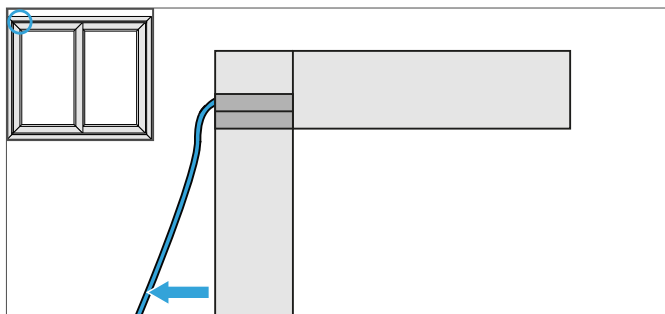

15. Insert the filling piece into the locking side of the guiding rail.

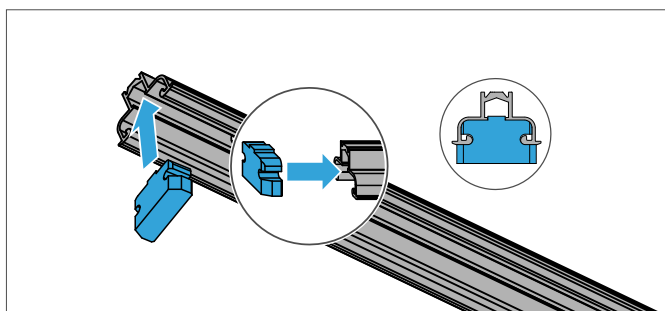

16. Loosen the fixing of the outer clamping piece.

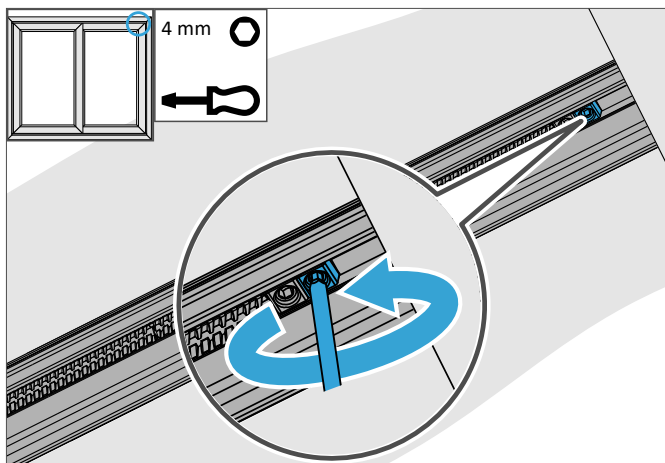

## Assembly instructions

DRIVE axxent LS timber elements

17. (1) Push both clamping pieces together with the tooth segments using a slotted screwdriver (7 mm blade width) as far as the stop in the direction of the locking side. (2) The tooth segments must lie firmly in place on the charging contact.

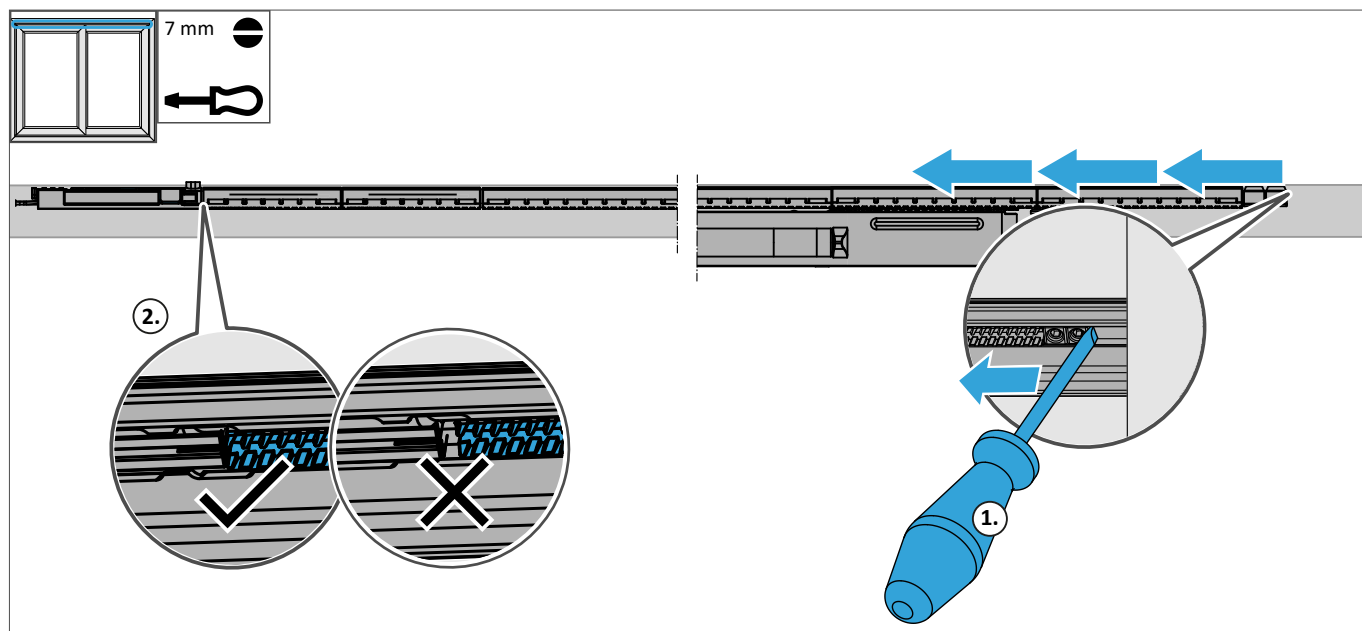

18. Fix the outer clamping piece.

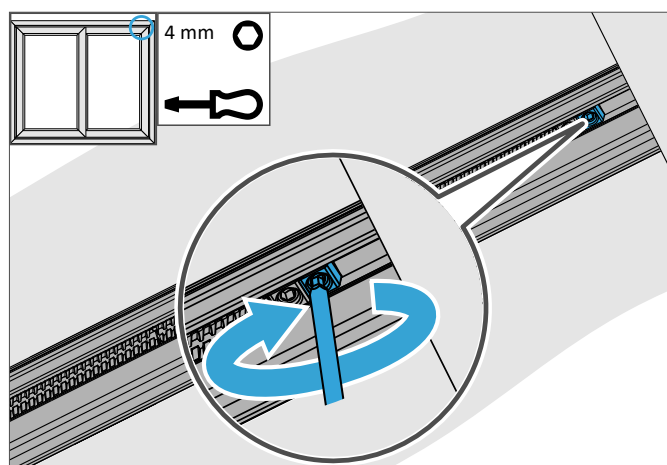

19. Insert a slotted screwdriver (7 mm blade width) with the narrow side between the clamping pieces. Turn the screwdriver  $\pm 90$  degrees and maintain the tension.

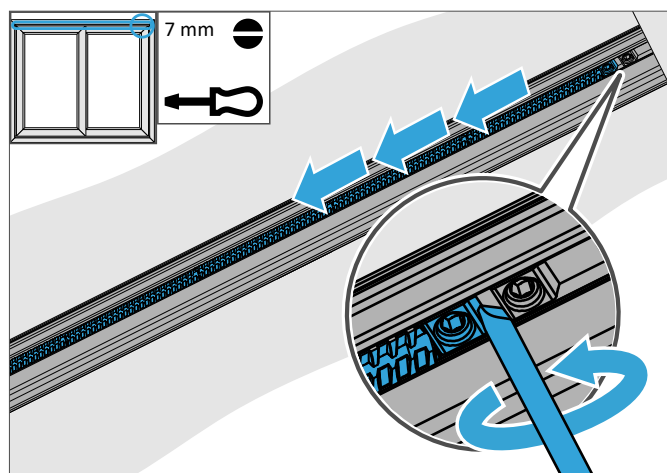

20. Fix the inner clamping piece.

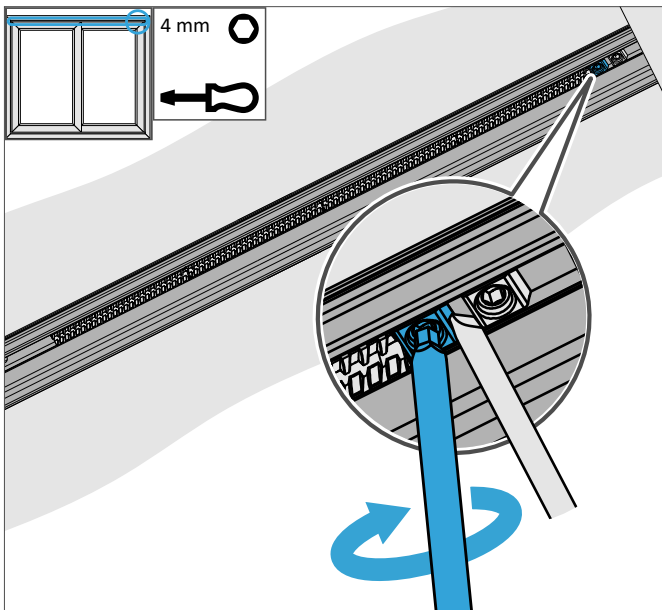

21. Loosen the fixing of the outer clamping piece.

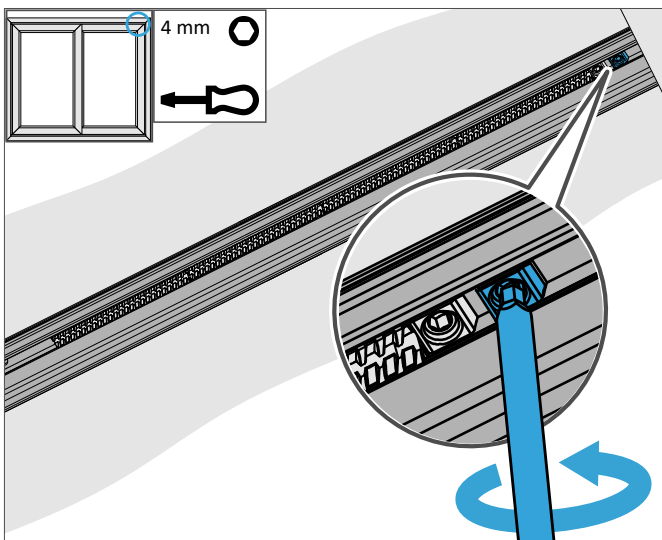

22. Push the outer clamping piece as far as the stop in the direction of the inner clamping piece.

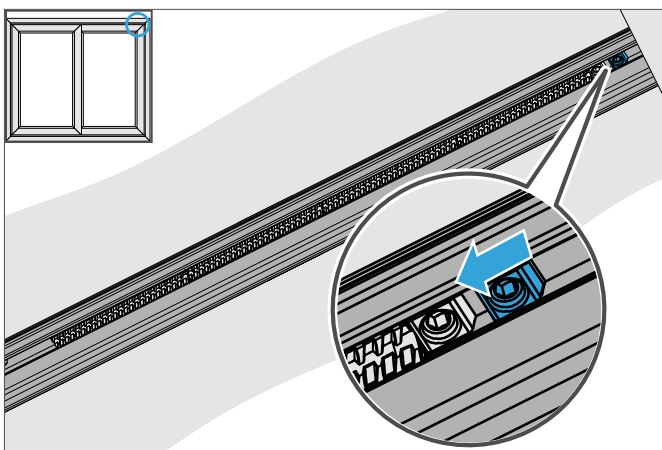

# Assembly instructions

DRIVE axxent LS timber elements

23. Fix the outer clamping piece. Torque: 4 Nm.

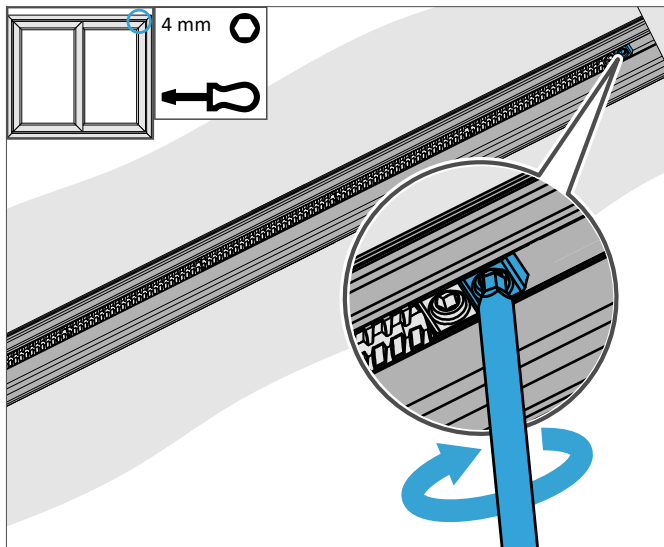

24. Cover the connecting cable of the charging contact with the cover rail. Clip cover rail into the guiding rail to do this.

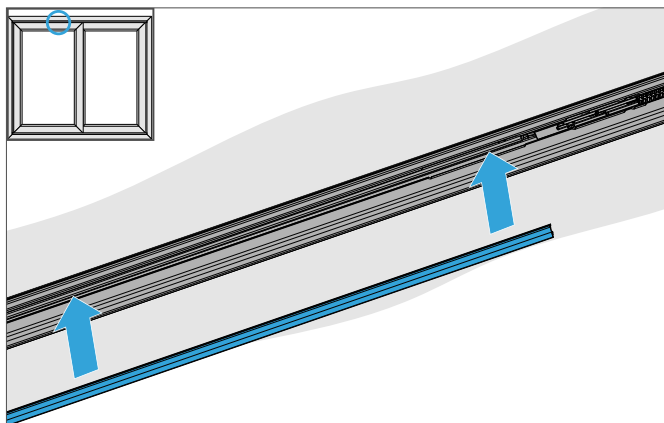

## 4.4 Processing sliding sashes

### 4.4.1 Holes for the button panel profile version Classic and Standard

1. Measure and mark the button position "T".

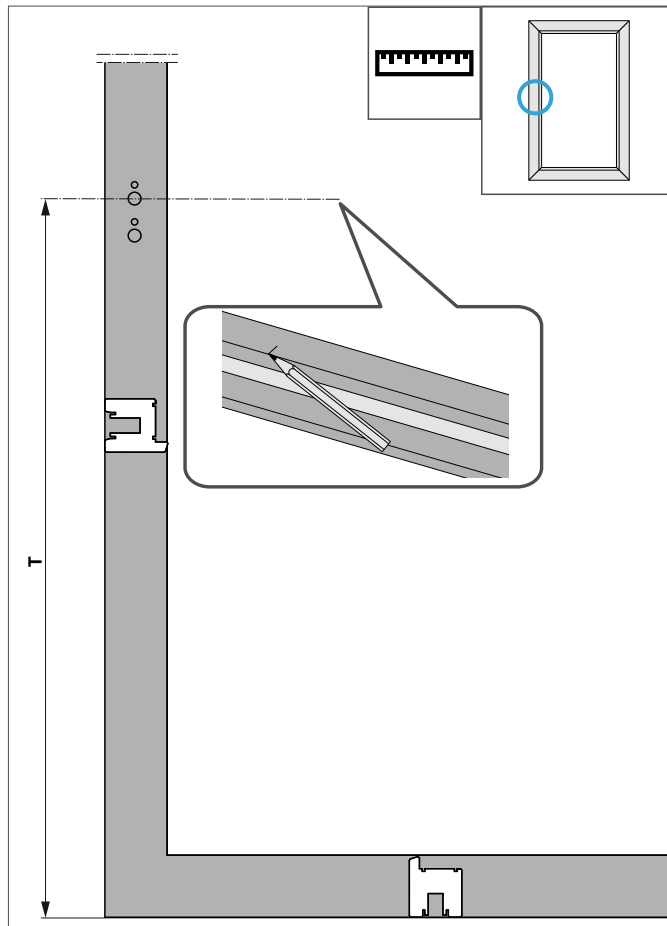

High running rail	Button position "T"
0 mm	1148 mm
5 mm	1153 mm
15 mm	1163 mm

2. Position the PAMR0210 jig correctly on the mark on the sliding sash. The arrows on the jig must always point upward for the correct DIN direction.

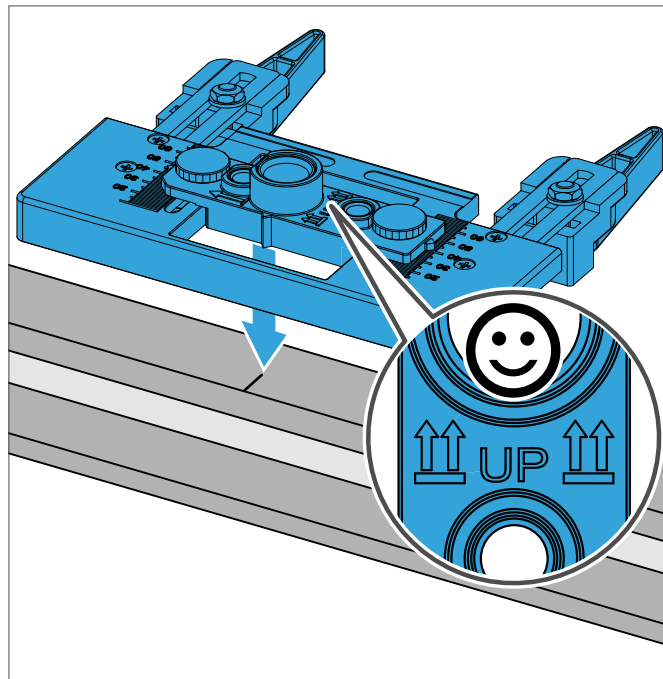

3. Fix the jig to the sliding sash.

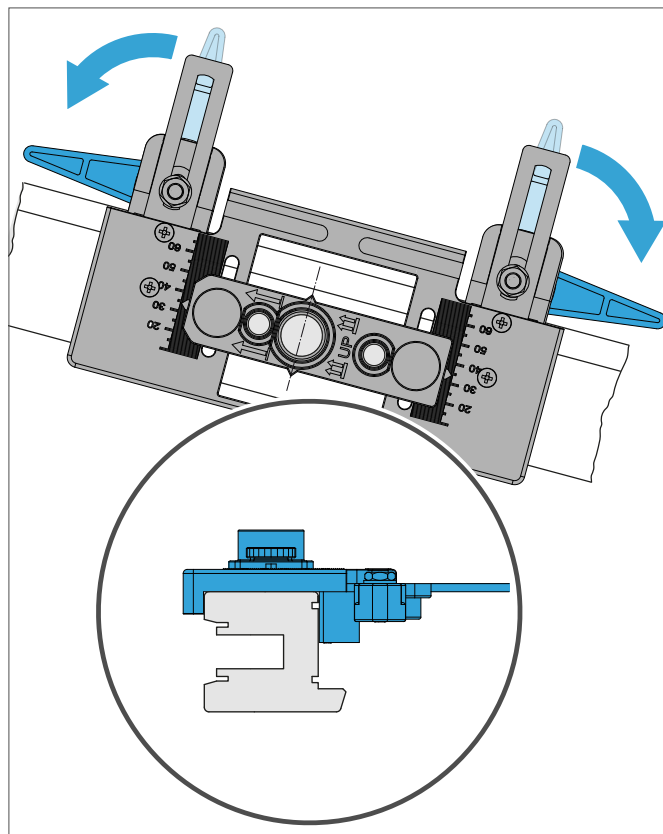

EN

DE

# Assembly instructions

DRIVE axxent LS timber elements

- Adjust the backset "D" on the jig, laterally from the sash edge according to the specification of the table.

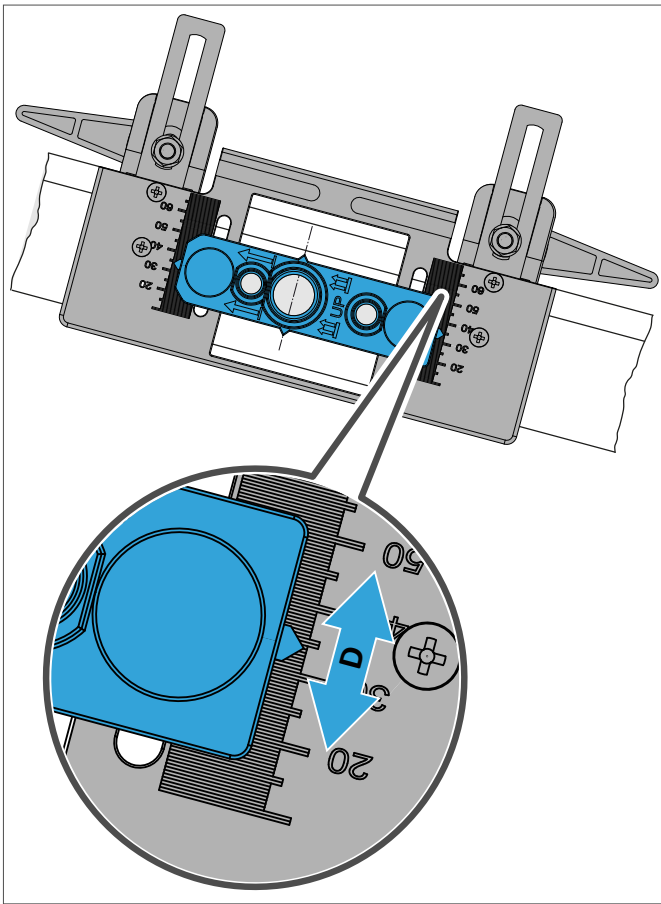

Backset "D" (horizontal axis)

Profile design	Jig adjustment
HS 4.0 Classic 78 mm frame width	32 mm
HS 4.0 Standard 92 mm frame width	36 mm

Drill only as far as into the fittings groove.

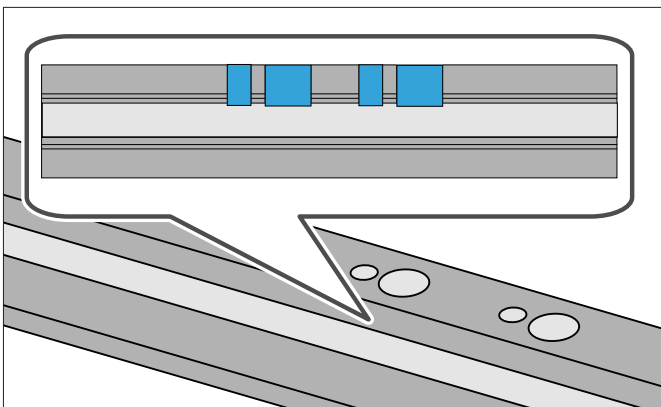

- Drill the hole group  $\varnothing 10$  mm and  $\varnothing 20$  mm out.

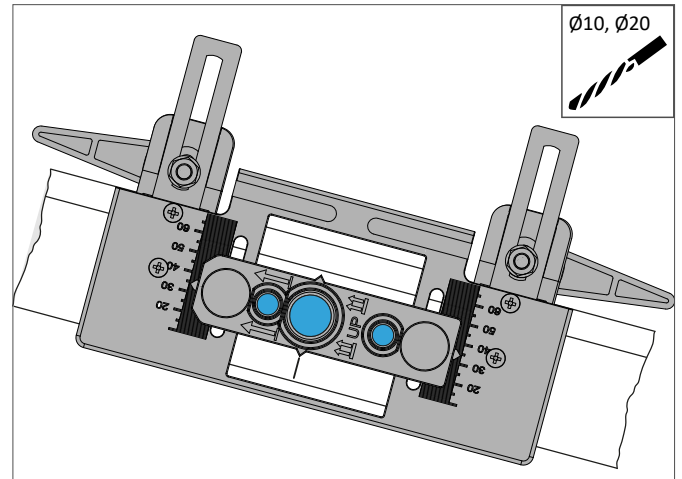

- Open the locking mechanism of the jig.

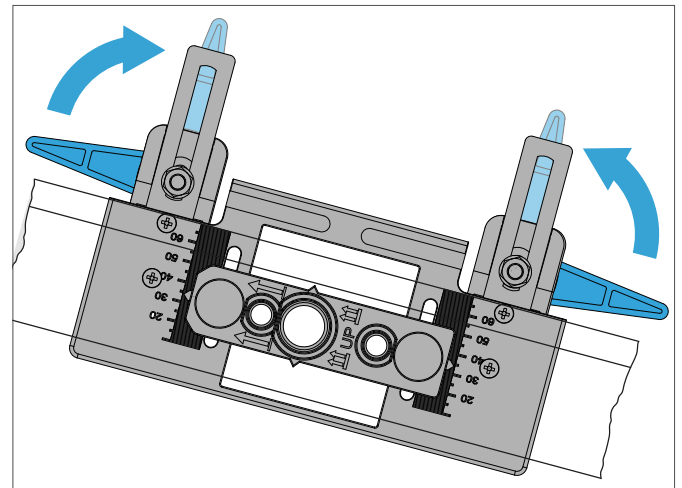

3. Move the jig downward. (1) The upper opening  $\varnothing 10$  mm of the jig and the lower hole  $\varnothing 10$  mm in the sash must be identical. (2) Secure the overlap with a  $\varnothing 10$  mm drill.

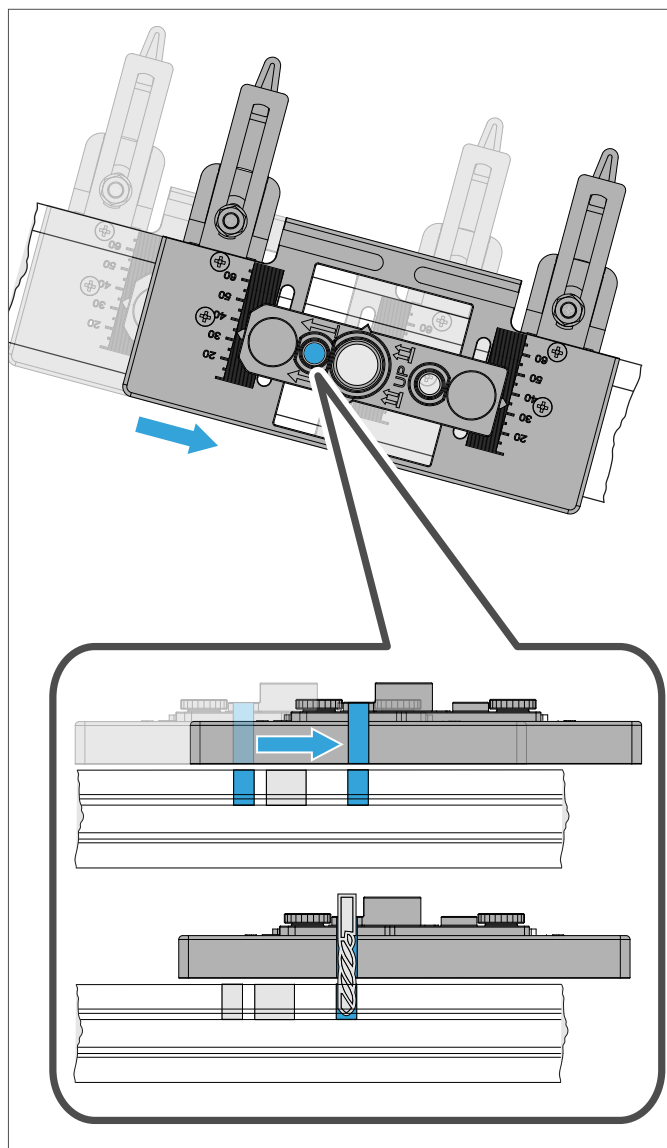

4. Fix the jig to the sliding sash.

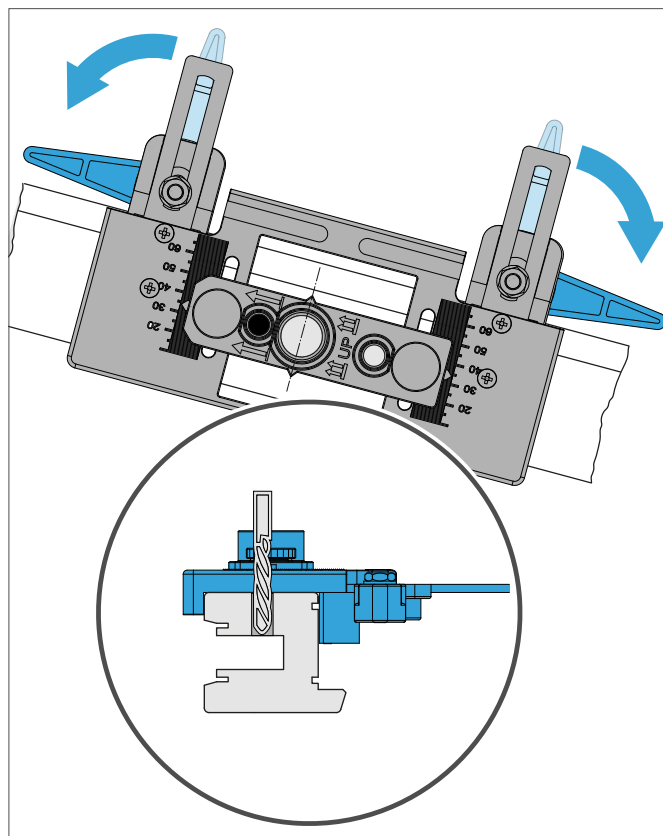

5. Drill the hole  $\varnothing 20$  mm.

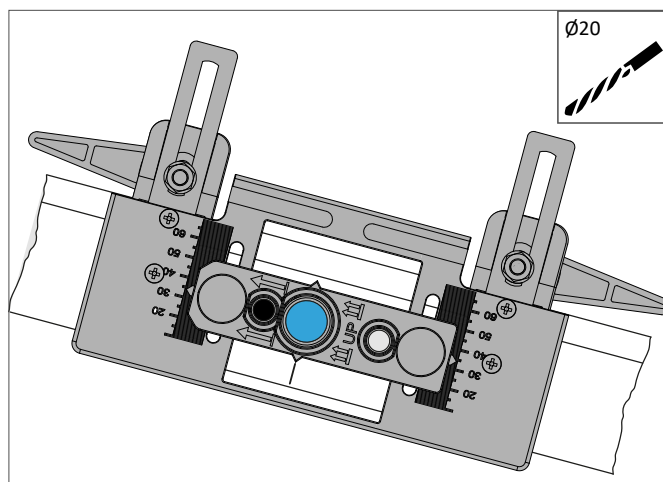

EN

DE

# Assembly instructions

DRIVE axxent LS timber elements

6. Open the locking mechanism of the jig and remove the jig.

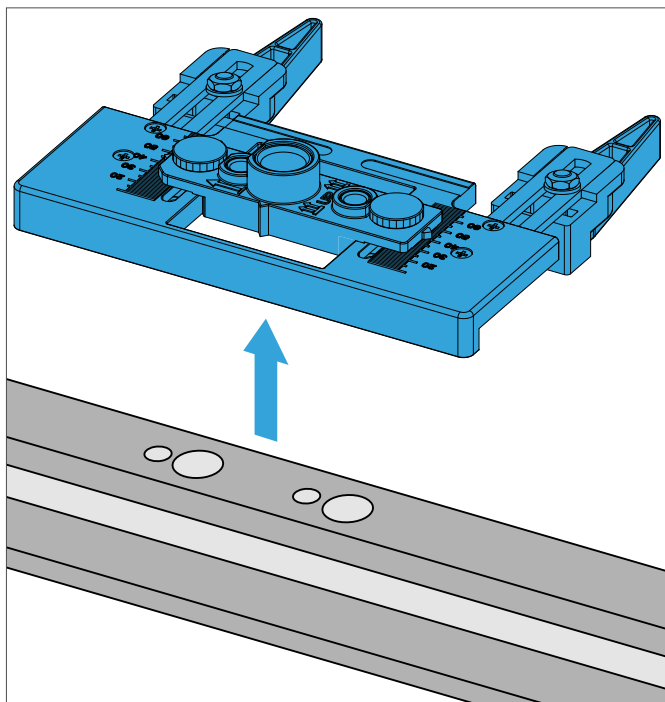

7. Bevel the holes  $\varnothing 20$  mm  $45^\circ \times 1$  mm.

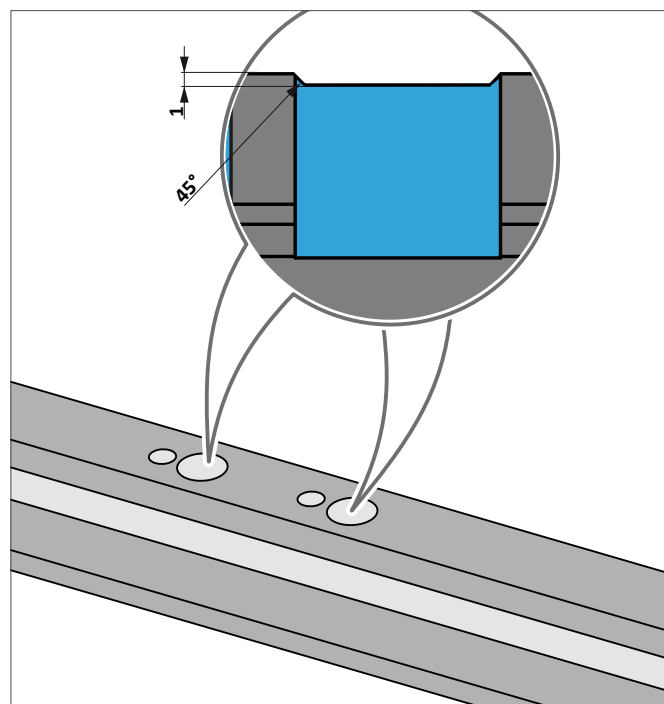

## 4.4.2 Holes for the button panel profile version slim

### Backset "D" slim (horizontal axis)

Profile design	Jig adjustment
HS 4.0 slim 60 mm frame width	20 mm

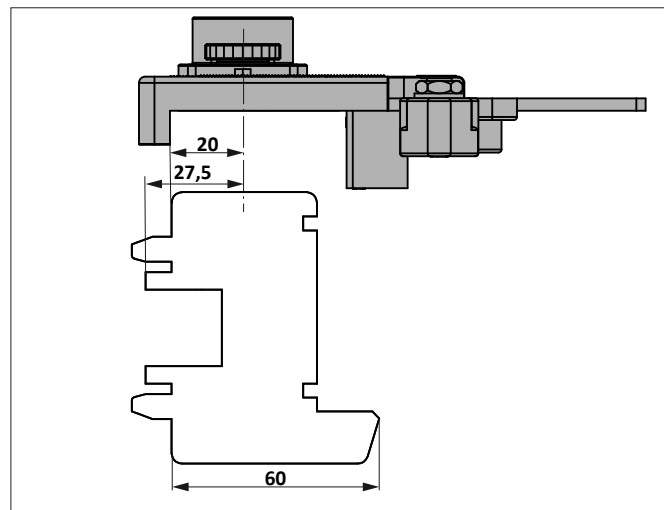

#### 4.4.3 Holes for the cable connection coupling shoe/battery

1. Position the jig PAMR0200 for the cable connection coupling shoe/battery in the fittings groove. Take the "Top" marking into account. Fix the jig using two screws 4.1 × 25 mm.

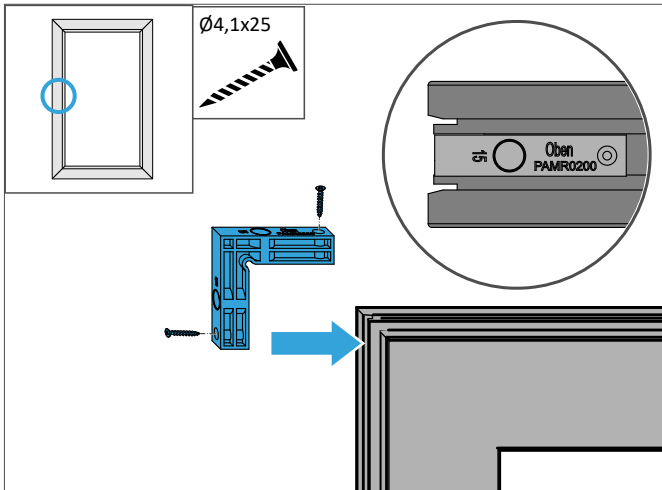

2. Drill horizontal and vertical holes with drill  $\varnothing 15$  mm so that they meet each other.

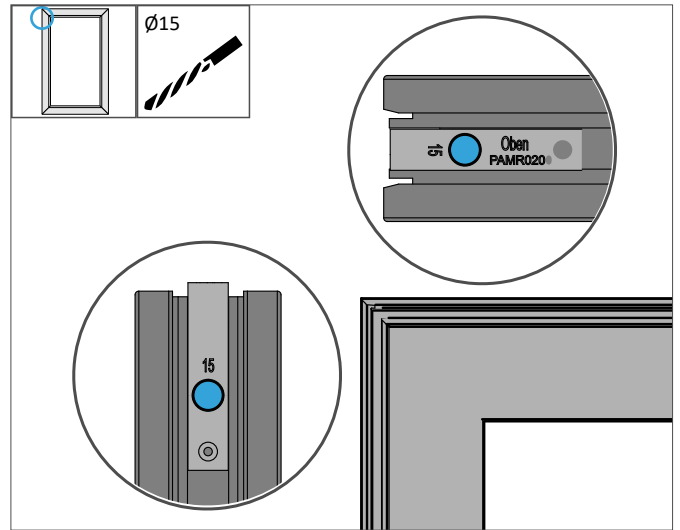

3. Unscrew the screws again and remove the jig.

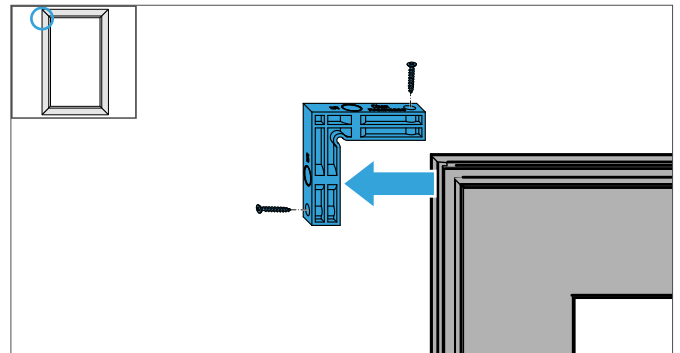

EN

DE

# Assembly instructions

## DRIVE axxent LS timber elements

### 4.4.4 Holes for the coupling shoe profile version Classic and Standard

1. Position the jig PAMR0010 for the coupling shoe in the fittings groove. Take the correct positioning point of the stop lug into account. Fix the jig using a screw 4.1 × 25 mm.

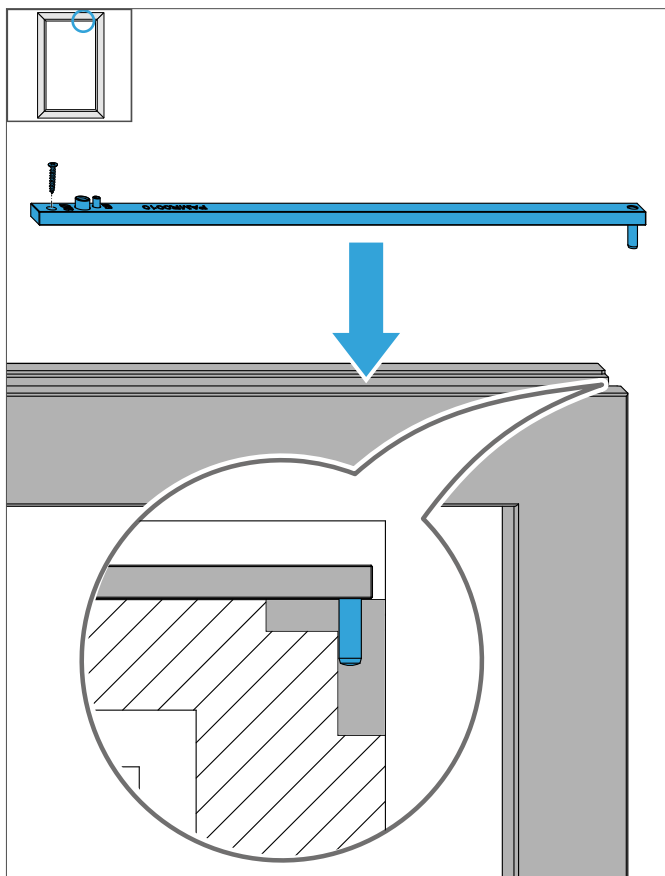

2. Drill the hole for the fixing pin of the coupling shoe with drill  $\varnothing 8$  mm - drilling depth 10 mm. Drill the hole for the fixing screw of the coupling shoe with drill  $\varnothing 3$  mm.

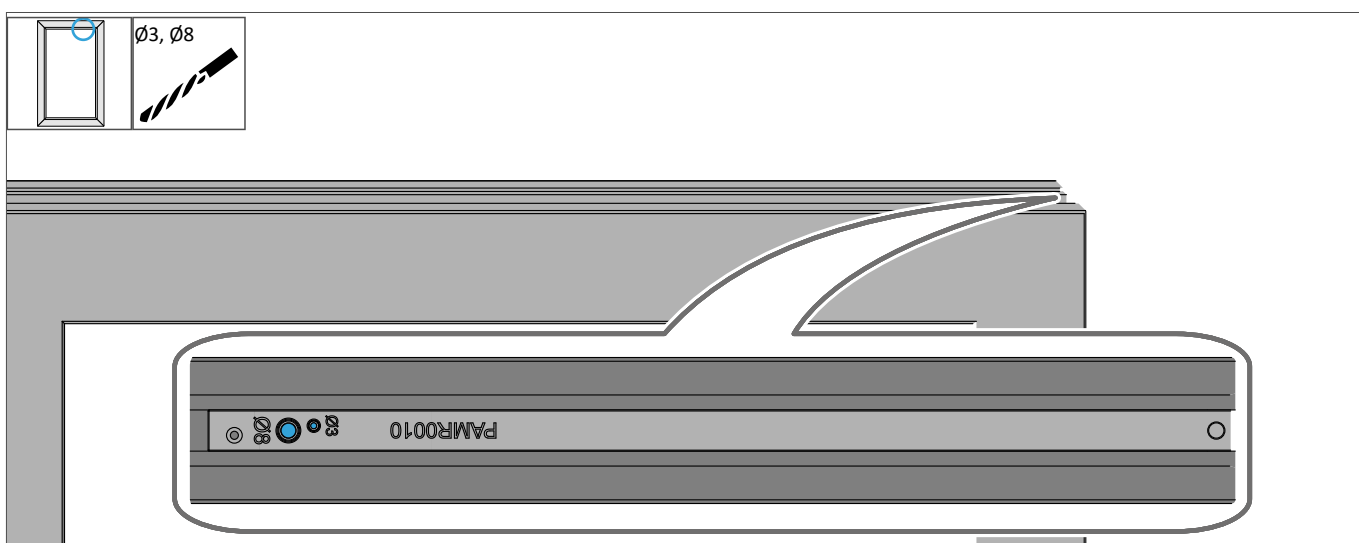

3. Unscrew the screw again and remove the jig.

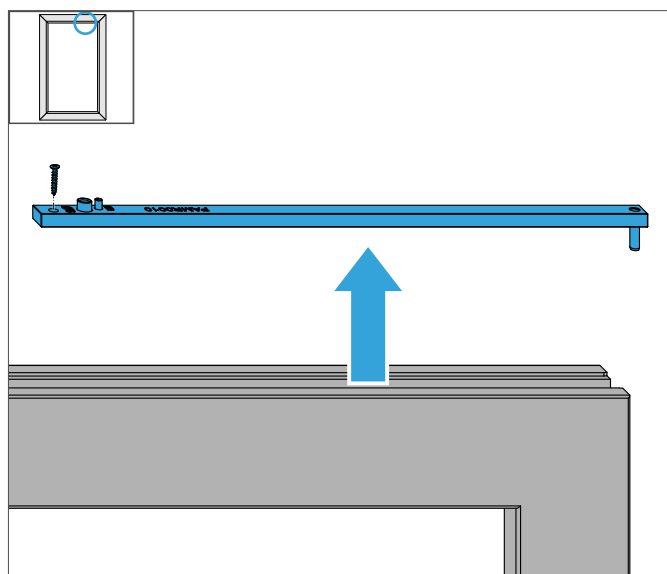

EN

DE

#### 4.4.5 Holes for the coupling shoe profile version slim

1. Position the jig PAMR0020 for the coupling shoe in the fittings groove. Take the correct positioning point of the stop lug into account. Fix the jig using a screw 4.1 × 25 mm.

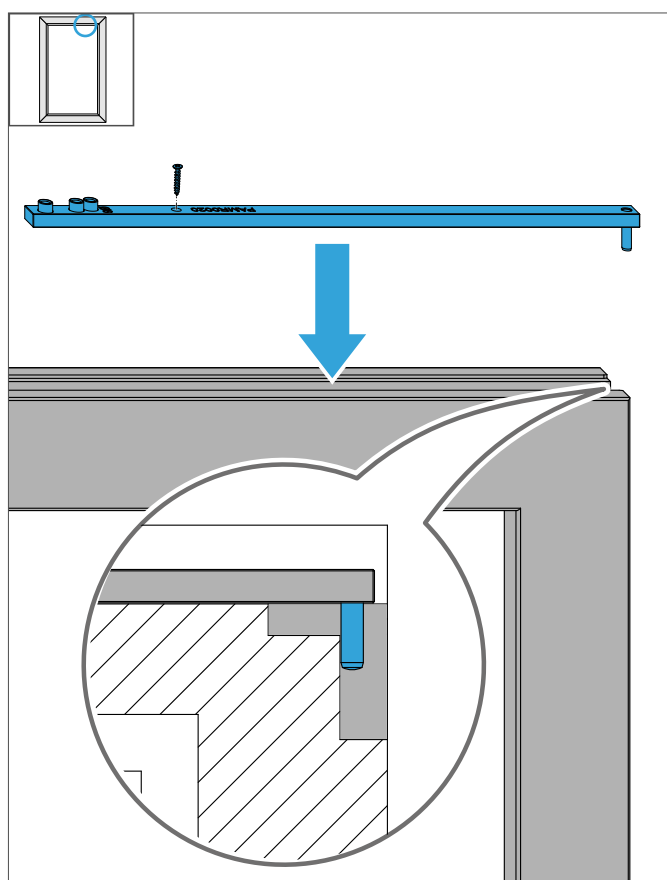

## Assembly instructions

DRIVE axxent LS timber elements

2. Drill the hole for the fixing pin and the screw-in sleeves M5 of the coupling shoe with drill  $\varnothing 8$  mm - drilling depth 10 mm.

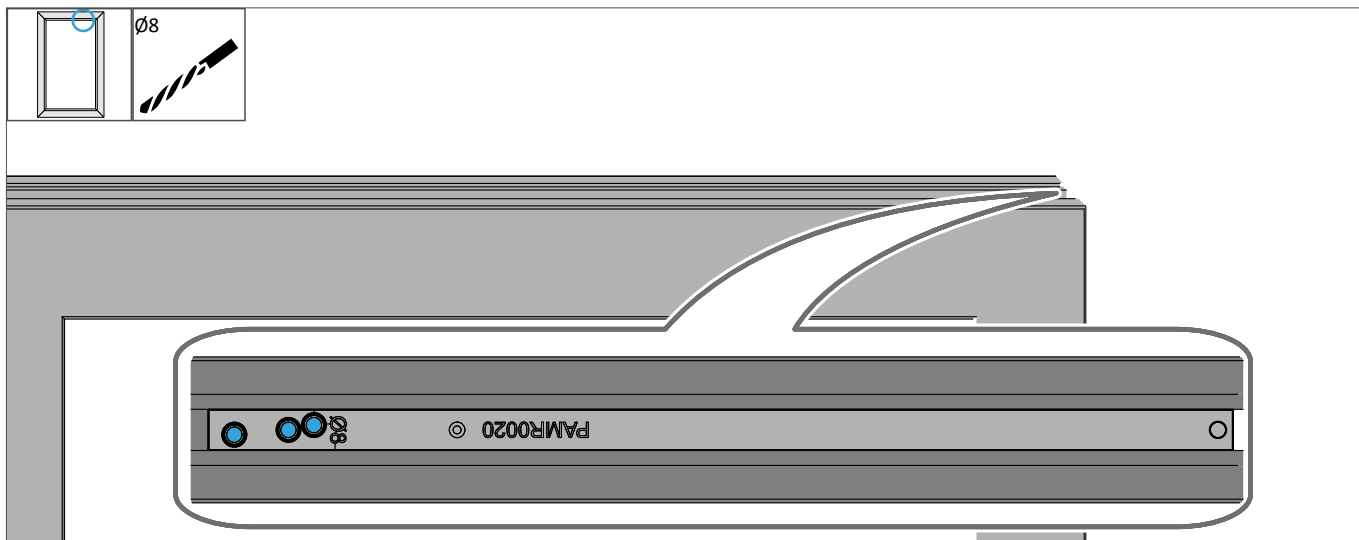

3. Unscrew the screw again and remove the jig.

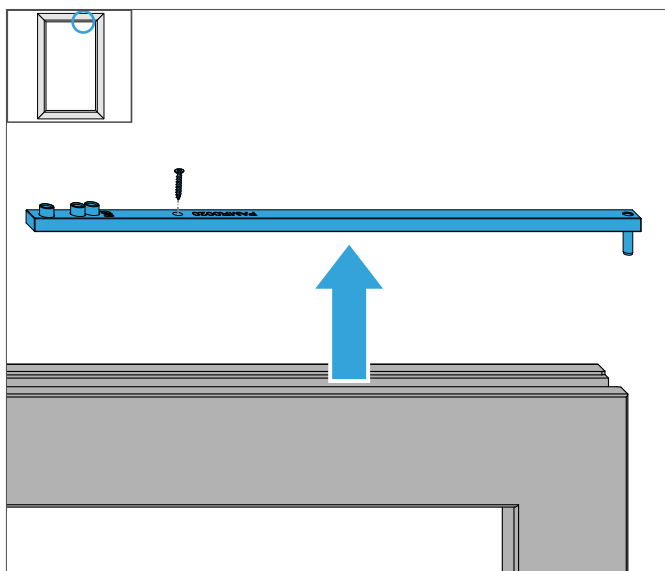

## 4.5 Installing leaf parts

### 4.5.1 Installing the lift drive and the operator push button

1. Press the sockets into the  $\varnothing 10$  mm holes. Insert the sockets flush with the profile.

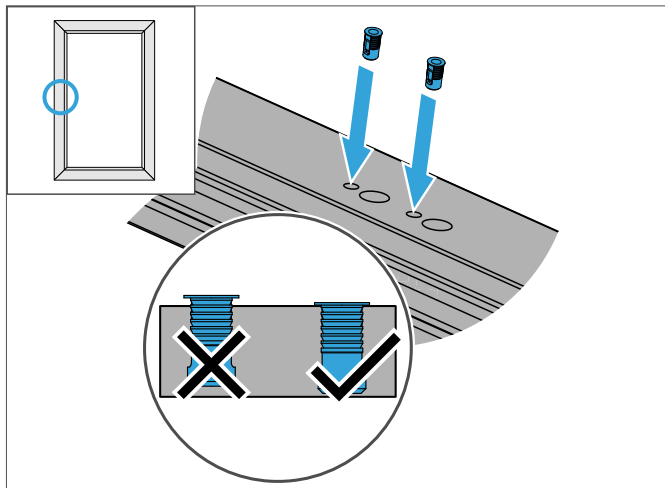

2. Guide the operator push button cable through the top  $\varnothing 20$  mm hole. Do not fix the operator push button yet.

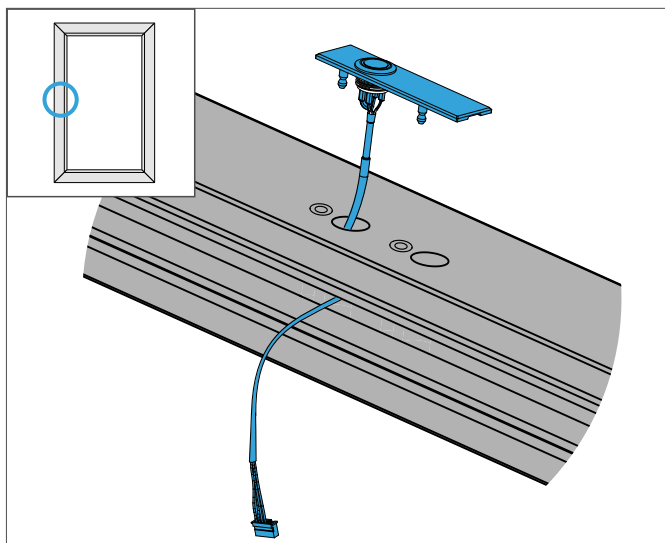

EN

DE

# Assembly instructions

## DRIVE axxent LS timber elements

3. Insert the plug on the operator push button cable into the corresponding bushing on the lift drive. Ensure that the clip lugs snap into place correctly.

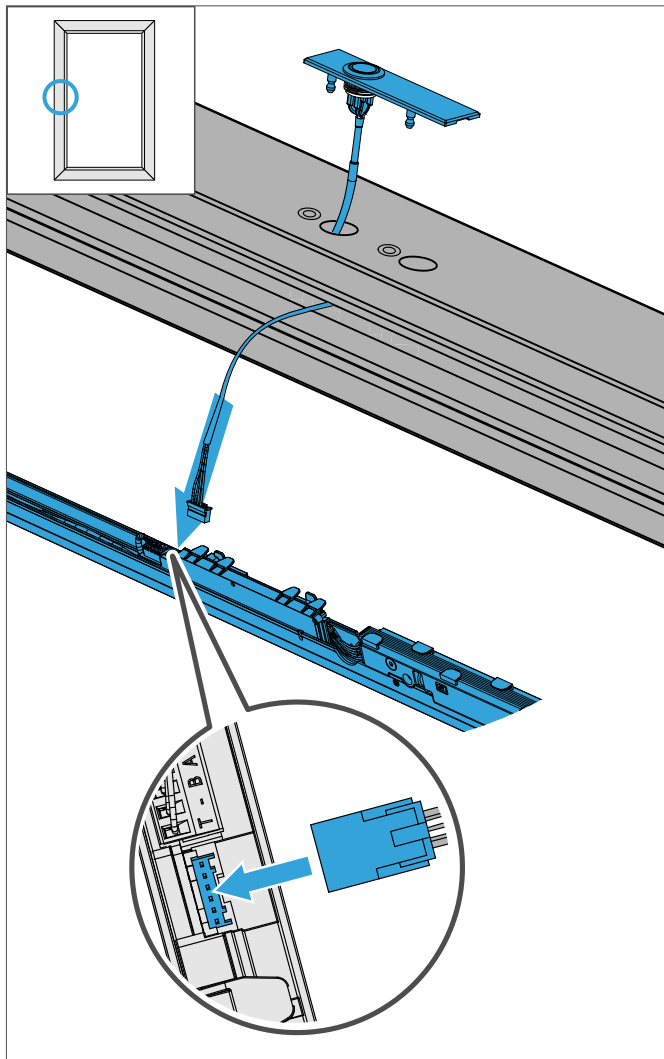

EN

DE

4. Stow the operator push button cable behind the brackets of the lift drive. Pivot the lift drive into the fittings groove and connect with the bogie wheels unit as described in the profile-specific assembly instructions. Screw the lift drive firmly into place.

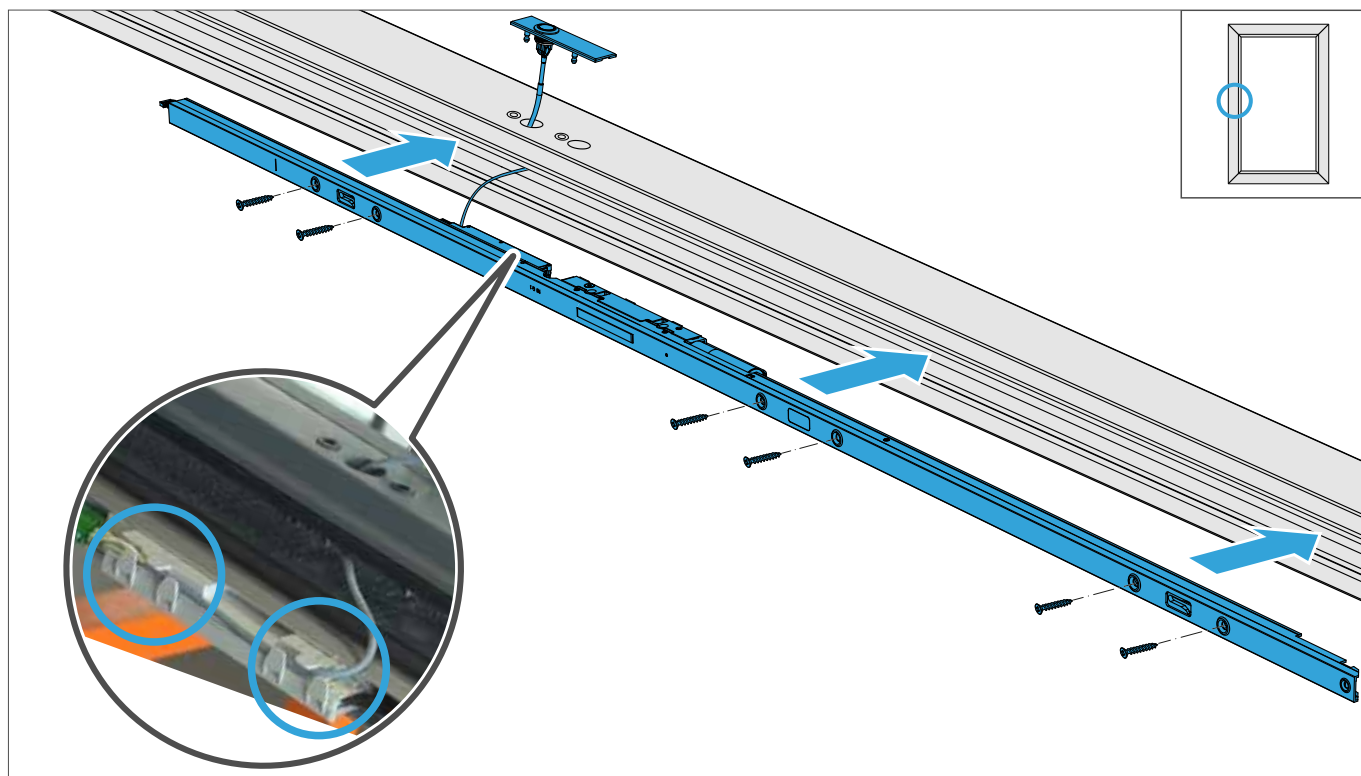

5. Stow the operator push button cable in the assembly opening. Press the operator push button into the sockets.

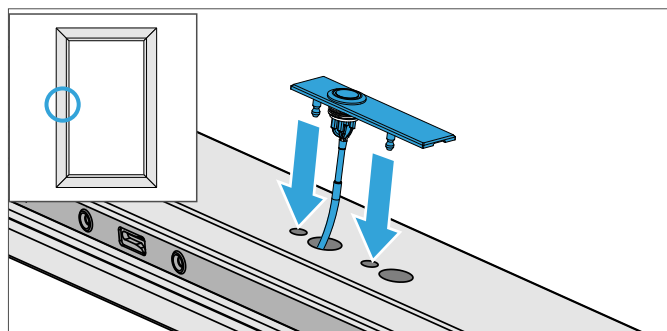

# Assembly instructions

DRIVE axxent LS timber elements

## 4.5.2 Installing the coupling shoe in the profile version Classic and Standard

1. Insert the coupling shoe with fixing pin into the hole  $\varnothing 8$  mm and screw tightly into place.

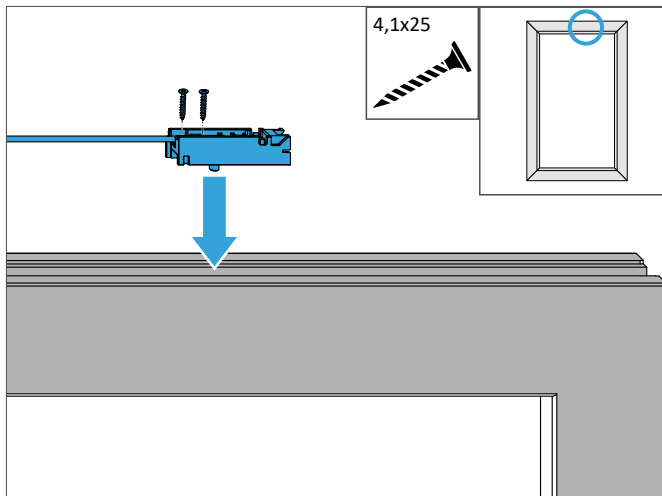

2. Guide the plug end of the cable through the holes  $\varnothing 15$  mm.

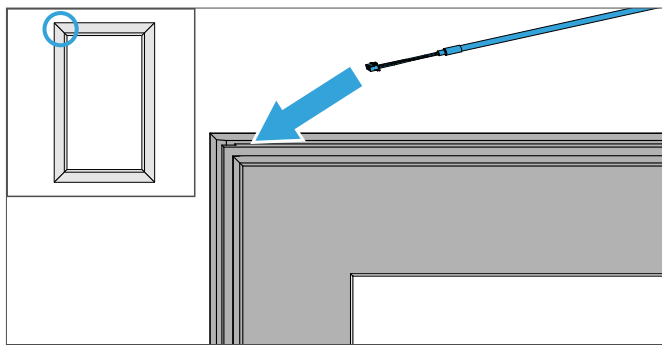

3. Position the plug end of the cable 25 mm before the sash edge and fix with a hold-down clamp.

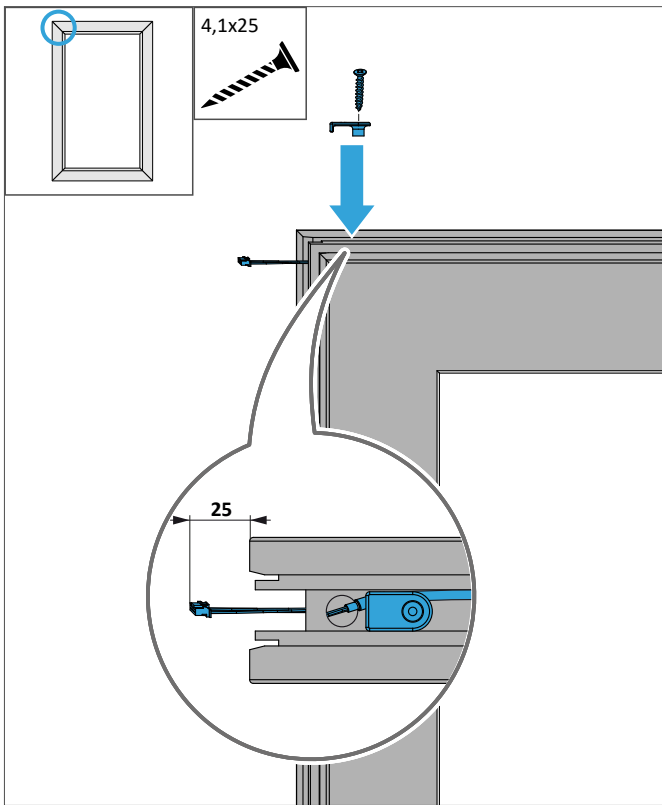

4. Lay the rest of the cable pulled in the fittings groove. The cable must not bulge up in the direction of the casement frame. Fix the rest of the cable with retaining plates as required.

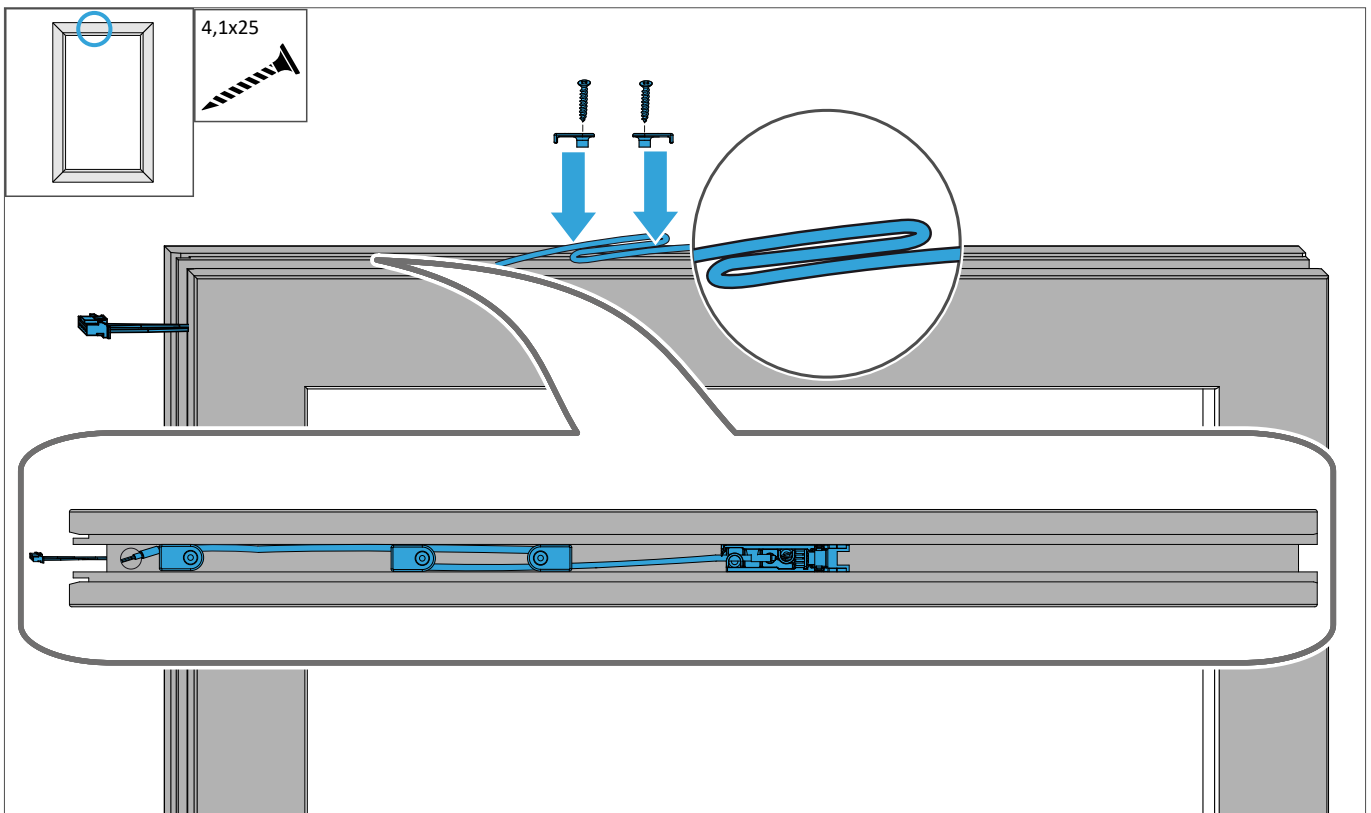

EN

DE

## Assembly instructions

DRIVE axxent LS timber elements

### 4.5.3 Installing the coupling shoe in the profile version slim

1. The insertion aid HS slim PABB0740 is required for the insertion of the screw-in sleeve M5 into the profile. Assemble the insertion aid as shown prior to installation.

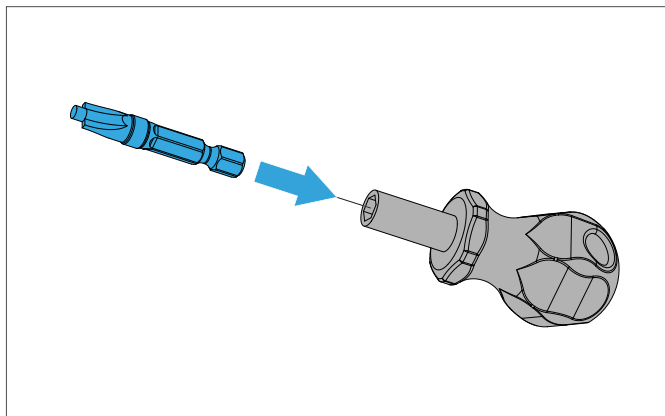

2. Insert the jig for the insertion of the screw-in sleeves M5 correctly into the hole of the fixing pin. Lay the screw-in sleeves M5 in the jig with the screwdriver slot facing upwards.

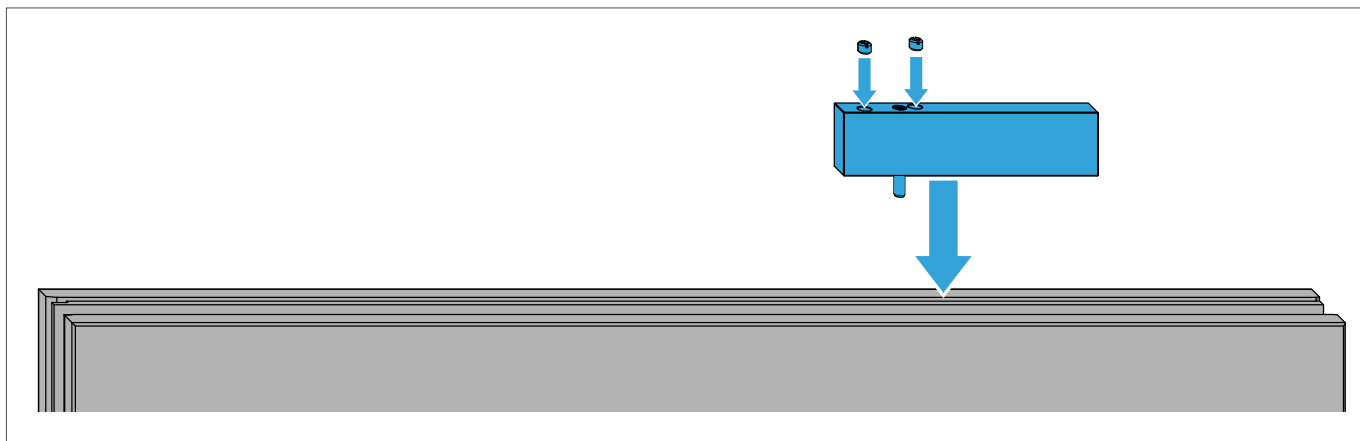

3. Screw in the screw-in sleeves M5 with the insertion aid to be flush with the profile.

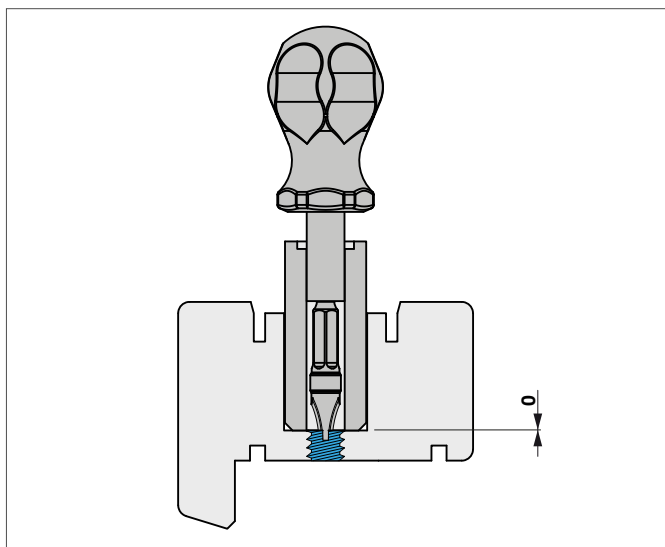

4. Insert the coupling shoe with fixing pin into the hole  $\varnothing 8$  mm and screw tightly into place.

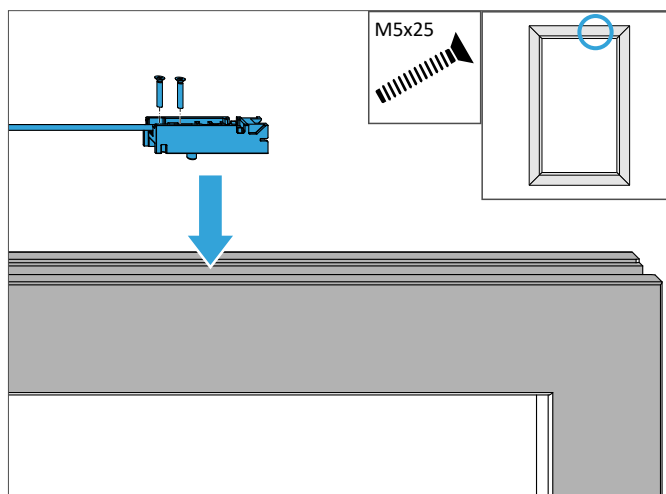

5. Guide the plug end of the cable through the holes  $\varnothing 15$  mm.

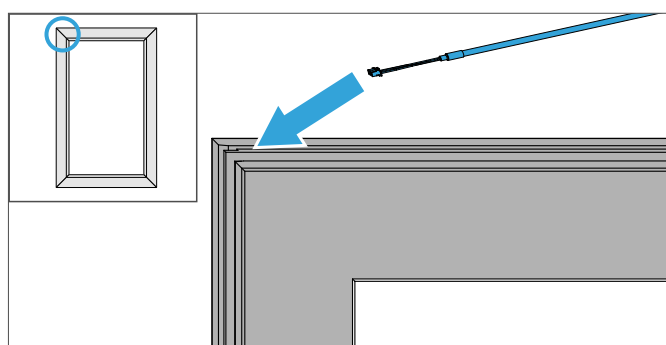

6. Position the plug end of the cable 25 mm before the sash edge and fix with a hold-down clamp.

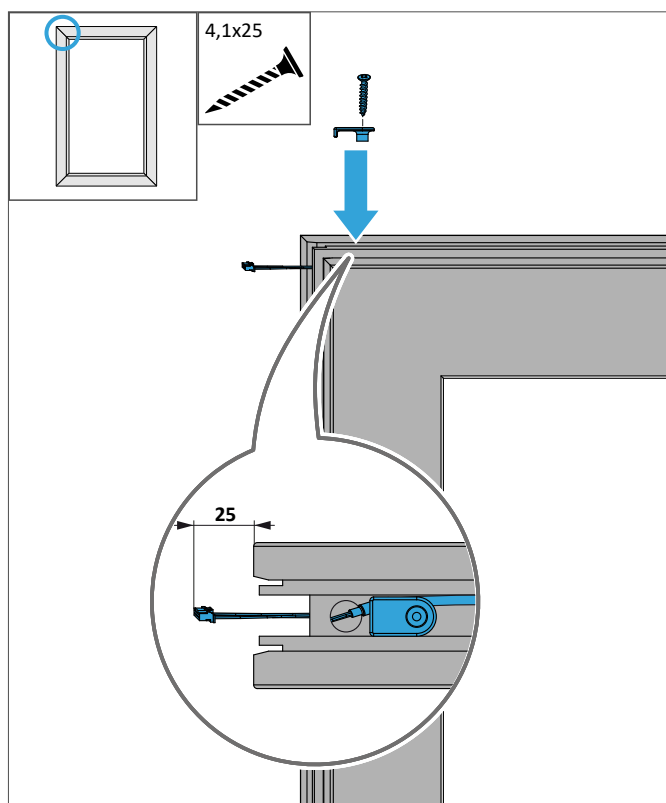

EN

DE

## Assembly instructions

### DRIVE axxent LS timber elements

7. Lay the rest of the cable pulled in the fittings groove. The cable must not bulge up in the direction of the casement frame. Fix the rest of the cable with retaining plates as required.

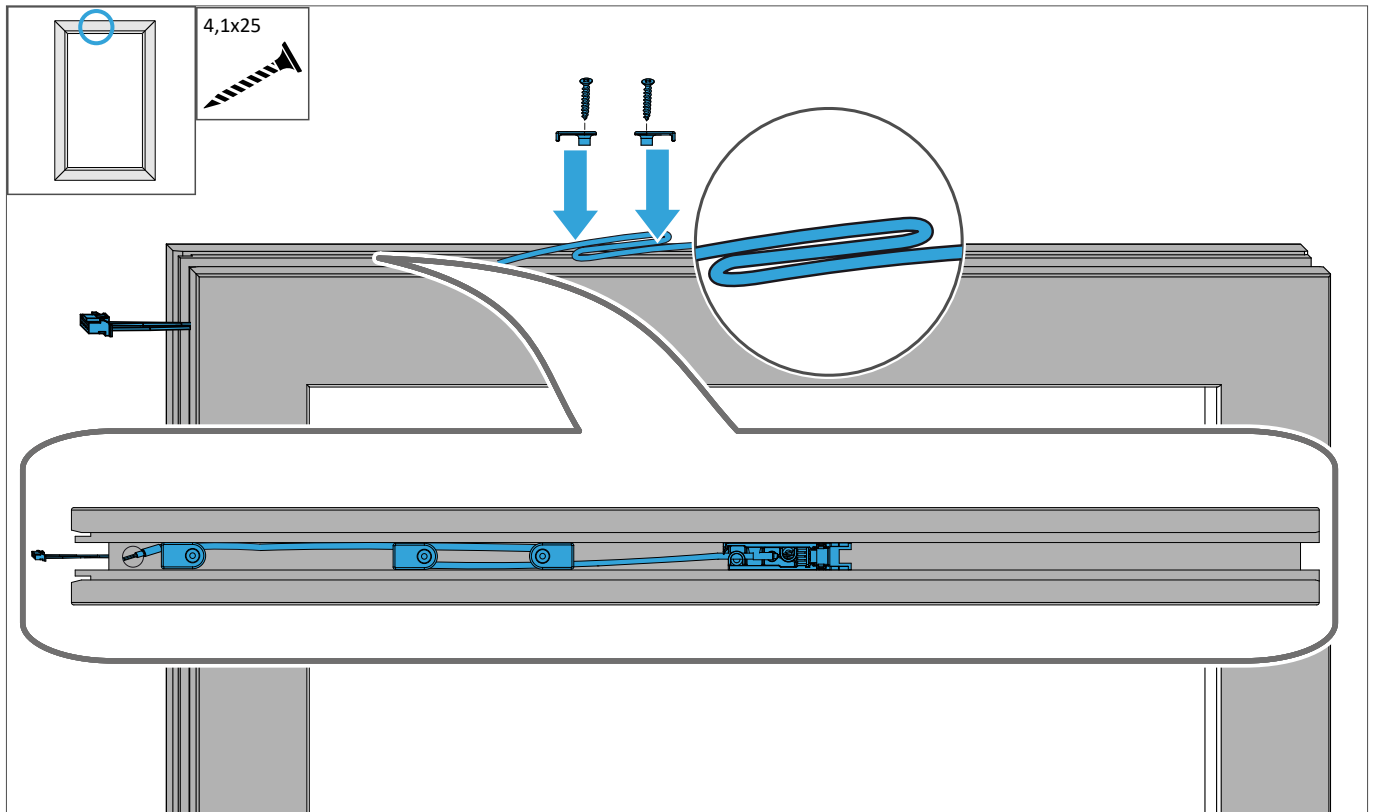

EN  
DE

#### 4.5.4 Installation of the battery pack

1. Connect the battery pack to the plug of the lift drive.

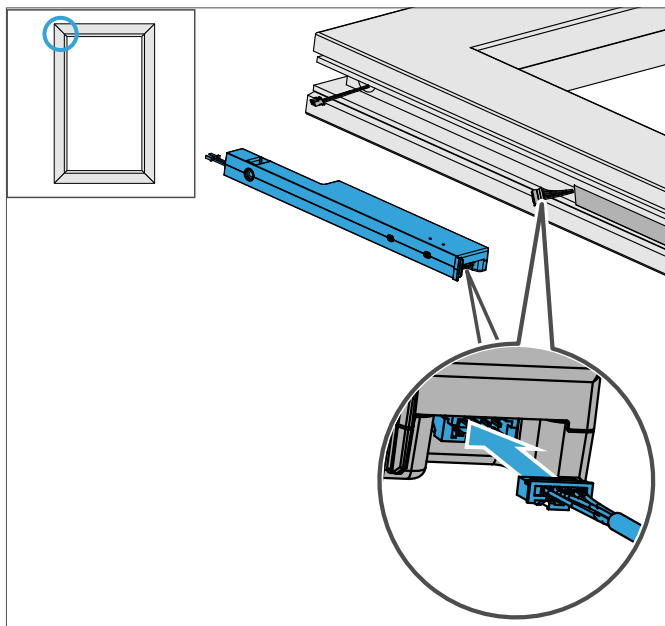

2. Connect the battery pack to the plug of the coupling shoe.

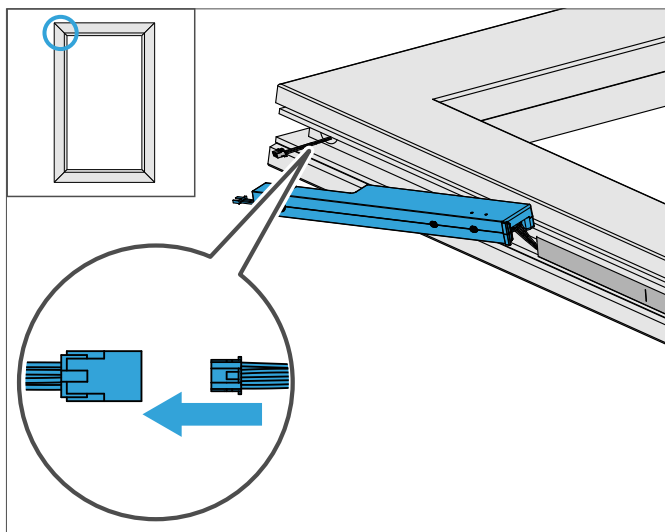

3. Mount the battery pack with the fastening lug on the secondary sash of the lift drive and swing the battery pack into the fittings groove.

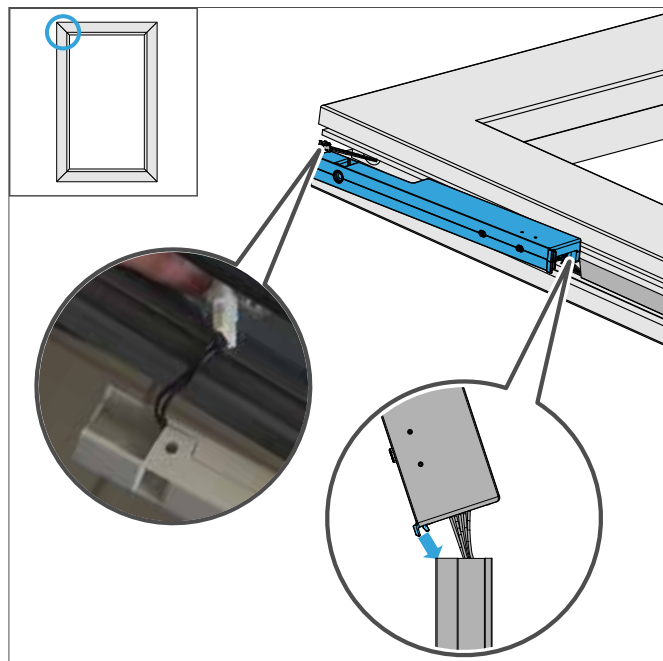

EN

DE

# Assembly instructions

DRIVE axxent LS timber elements

- 4. Lay the cable in the cable storage compartment and in the hole of the coupling shoe cable and do no damage. When laying, the cable must not bulge up over the edge of the sash.

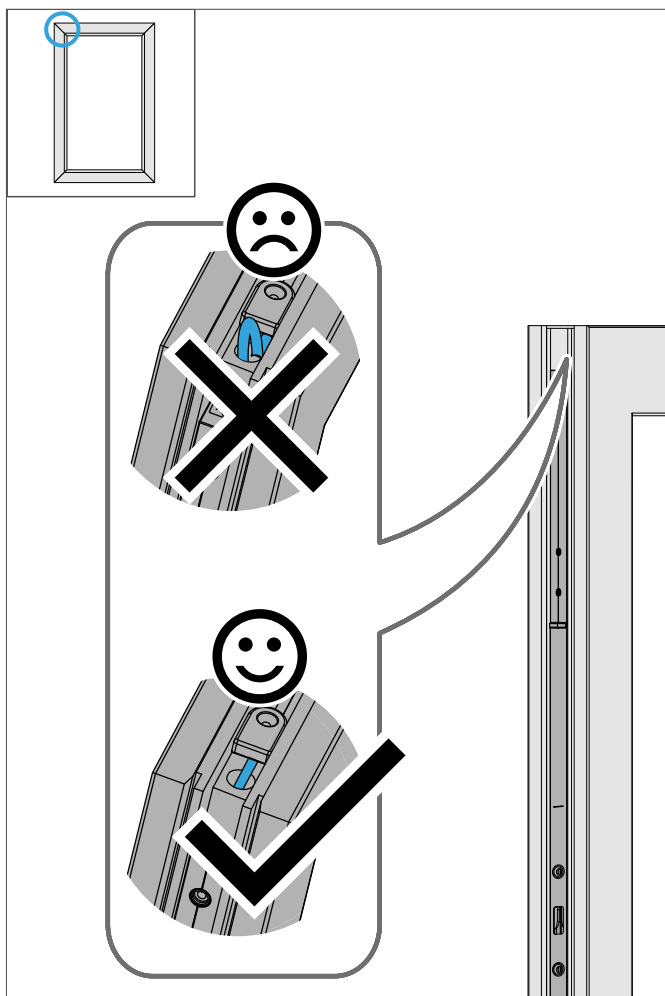

- 5. Screw the battery pack with a screwdriver and the accessory screw PAN head PZ 4.0 X 35 firmly in the fittings groove. The battery casing must not become deformed when tightening the accessory screw.

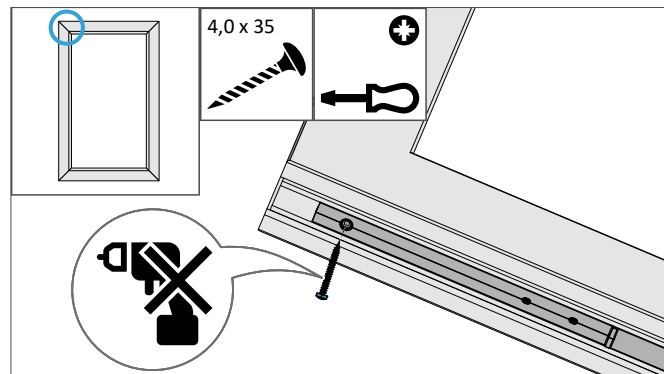

EN  
DE

#### 4.5.5 Pairing the battery pack with the lift drive

**Requirements:**

- The sliding sash is fully assembled.
- The sliding sash is on the fitting table.

1. Switch on the battery pack with a short press on the menu button.

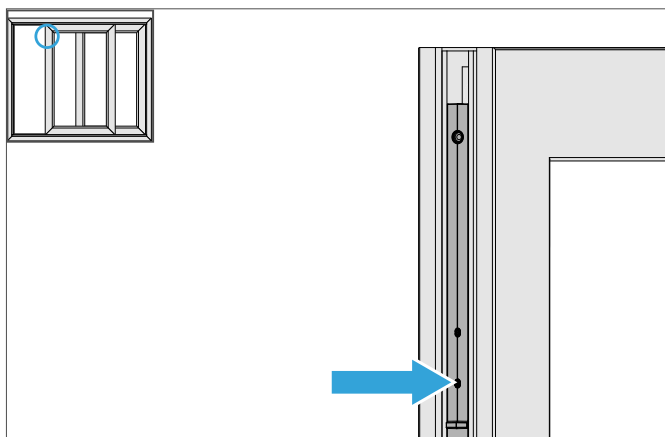

2. Start the pairing with a long press on the operator push button (cf. chapter "How it works").

- The long press is confirmed with a tone sequence.
- The status LED flashes turquoise
- The battery pack and the lift drive are made known to each other.

→ A tone sequence is emitted in the lift drive until the pairing is successful.

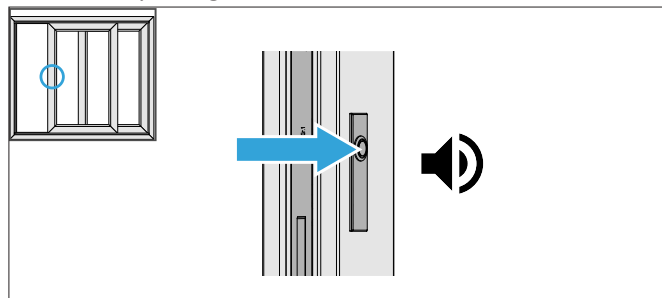

→ The pairing is done when an acoustic signal in the battery pack sounds and the status LED flashes magenta.

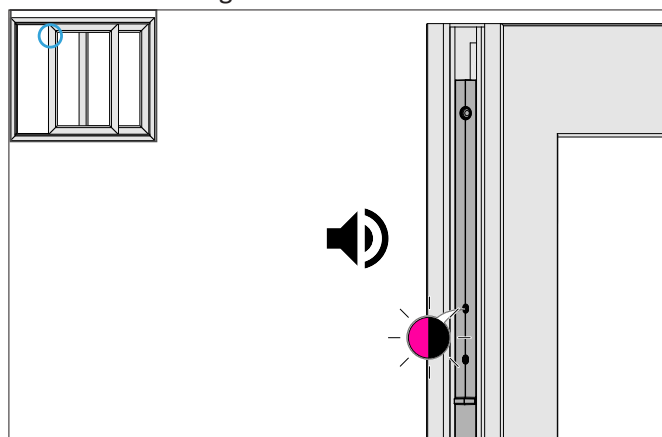

**As of now the lift drive can be raised and lowered with a short press on the operator push button. A long press on the operator push button restarts the pairing process.**

EN

DE

### 5 Commissioning workshop/installation site

The commissioning in the workshop is recommended.

**The commissioning at the installation site of the fully glazed lift and slide element is absolutely necessary.**

EN

DE

## 5.1 Inserting the sliding sash into the frame

### Prerequisites

- The sliding sash is fully assembled.
- The battery pack is paired with the lift drive.
- The sliding sash is on the fitting table.
- The sliding sash is in the lowered position.

1. Switch on the battery pack with a short press on the menu button.

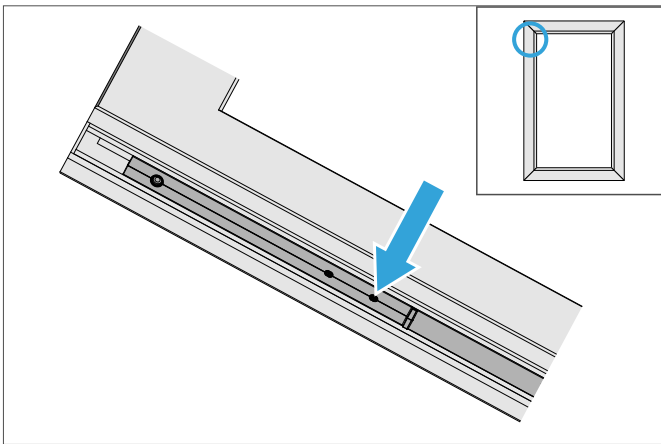

2. Bring the lift drive to the raised position with a short press on the operator push button.

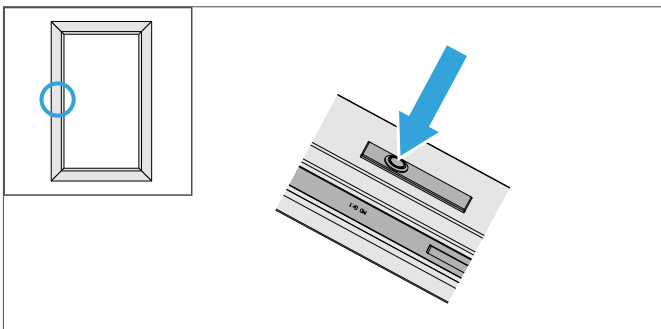

3. Place the sliding sash on the running rail.

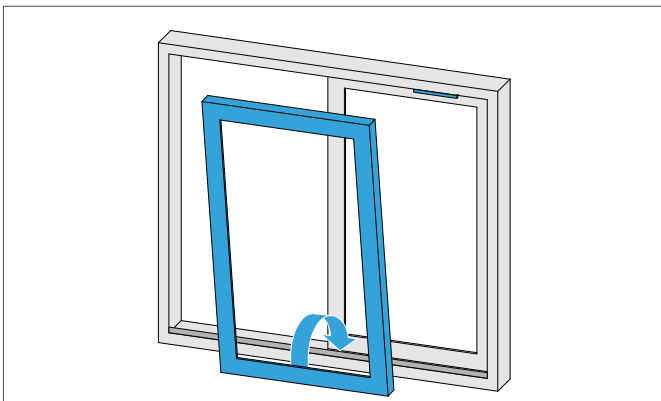

4. Tilt the sliding sash into the frame. The slide drive must not be in the way during the course of this.

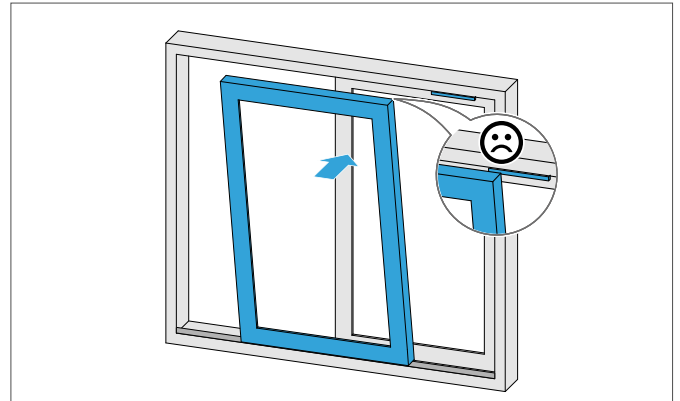

5. Push the front guide into the sliding sash and screw firmly.

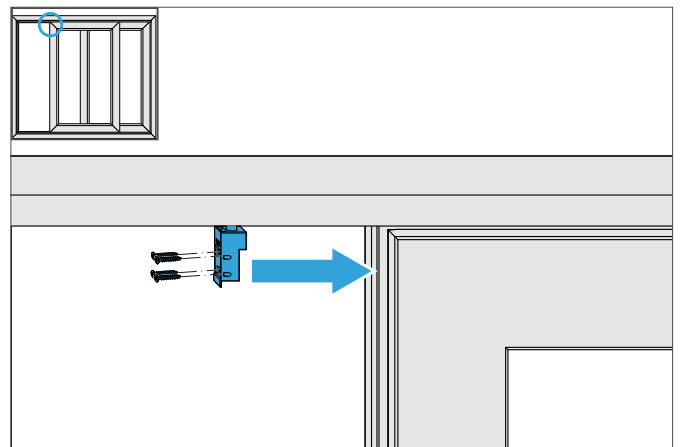

6. Push the sliding sash slowly by hand into the slide drive and screw firmly.

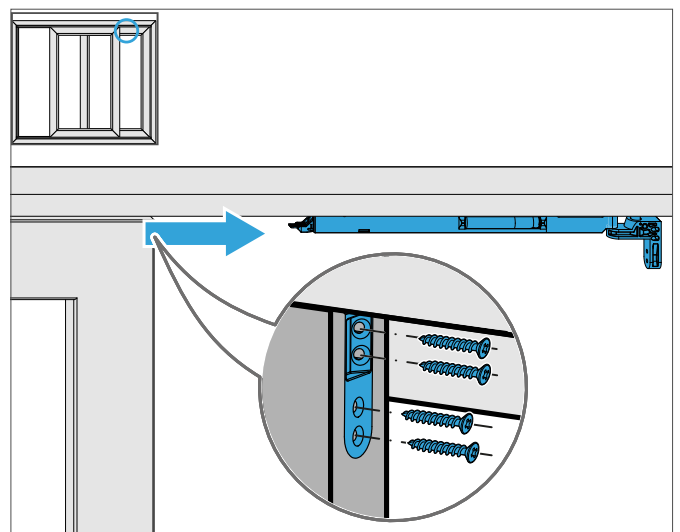

EN

DE

### 5.2 Operator push button functions by modes

#### 5.2.1 Pairing mode

- Short press > An acoustic signal sounds, otherwise no function.
- Long press > An acoustic signal sounds; the users are searched for and paired. If only the lift drive is found, it can be raised and lowered by the short press.

If all users are found, the pairing mode is exited automatically and switches to the processor mode.

#### 5.2.2 Processor mode

- Short press > An acoustic signal sounds; toggle operation > Open – Stop – Close
- Long press > An acoustic signal sounds; the teach-in run is started.

- Constant press > The sliding sash is opened from the maximum opening position beyond the shearing safety range (hold-to-run operation).
- Constant press (10 seconds) > The processor mode is cancelled.

#### 5.2.3 Operator mode

- Short press > toggle operation > Open – Stop – Close
- Long press > An acoustic signal sounds. The intermediate position is reached.
- Constant press > The sliding sash is opened from the maximum opening position beyond the shearing safety range (hold-to-run operation).

### 5.3 Pairing the battery pack with the lift and slide drive

**⚠ WARNING**

**Danger of crushing due to deactivated jam protection**

The first press on the operator push button always results in the reference run. The jam protection is deactivated in the process. When the jam protection is deactivated, the moving element does not react to obstacles. This means that the element can crush or shear parts of the body.

- Stay within the range of vision of the moving element.
- Maintain safety clearance from the moving element.
- Keep people away from moveable elements.

**Prerequisites**

- The sliding sash is fully assembled.
- The sliding sash is inserted in the frame.

1. Switch on the battery pack with a short press on the menu button.

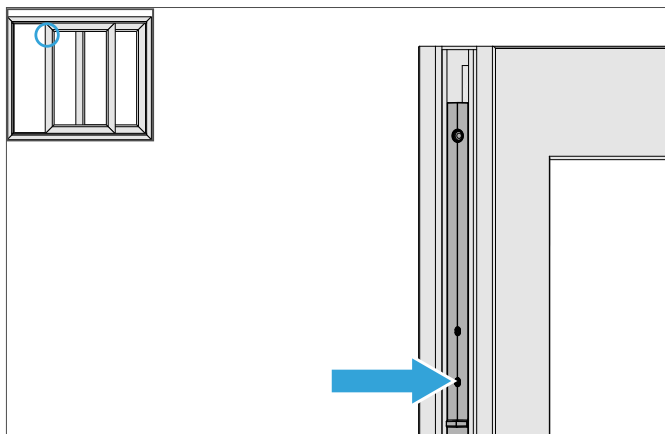

2. Start the pairing with a long press on the operator push button (cf. chapter "How it works").

→ The long press is confirmed with a tone sequence.

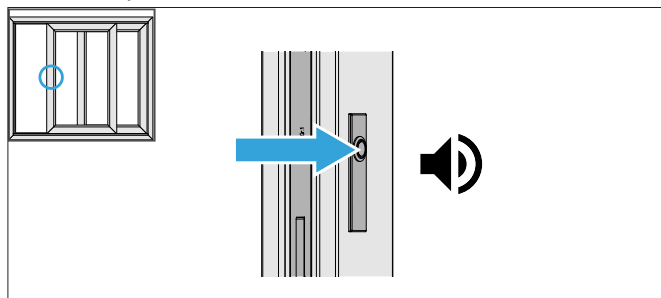

→ The battery pack, the lift drive and the slide drive are made known to each other.

→ Tone sequences are emitted in the lift drive and in the slide drive one after the other until the pairing is successful. The one drive is paired first, then the other.

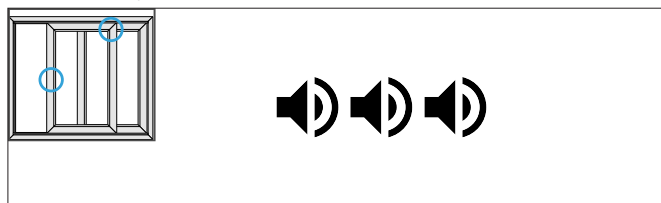

→ The pairing of the slide drive is done when an acoustic signal in the battery pack sounds and the status LED flashes dark blue.

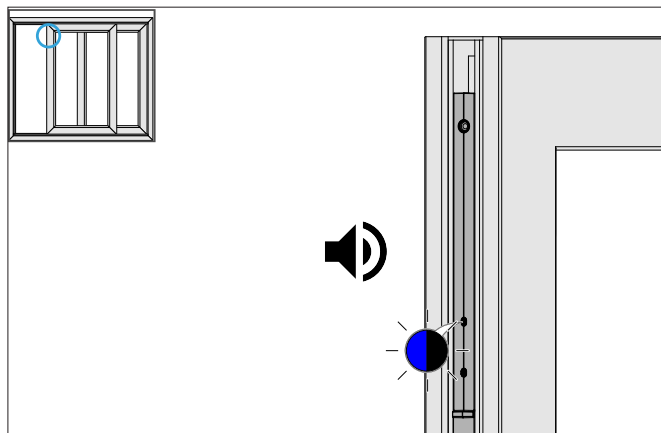

# Assembly instructions

## DRIVE axxent LS timber elements

→ The pairing of the lift drive is done when an acoustic signal in the battery pack sounds and the status LED flashes magenta.

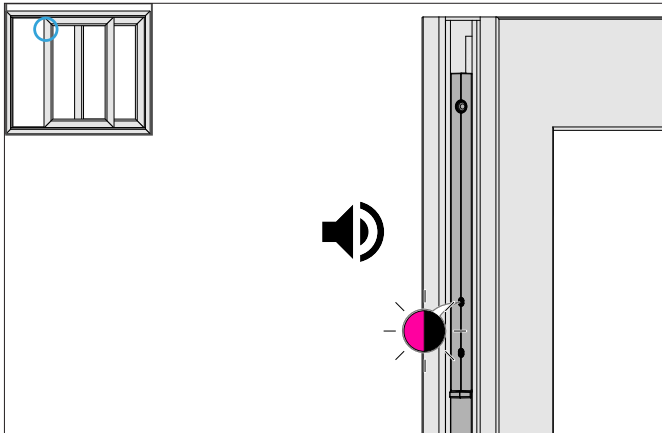

→ After the successful pairing of every user there is an automatic switch to the processor mode. As of now the lift and slide element can be operated with a short press. Until the successful teach-in run the maximum opening width will be 400 mm.

### 5.4 Perform reference run

#### Important notice:

Every time that the slide drive is separated from power, the first press on the operator push button triggers the reference run!

The reference run is also performed in these cases:

- after the initial assembly (pairing) of the slide drive
- when the battery pack is switched off
- when the slide drive is removed (e.g. during sliding sash removal)

#### ⚠ WARNING

##### Danger of crushing due to deactivated jam protection

The first press on the operator push button always results in the reference run. The jam protection is deactivated in the process. When the jam protection is deactivated, the moving element does not react to obstacles. This means that the element can crush or shear parts of the body.

- Stay within the range of vision of the moving element.
- Maintain safety clearance from the moving element.
- Keep people away from moveable elements.

1. Switch on the battery pack with a short press on the menu button.

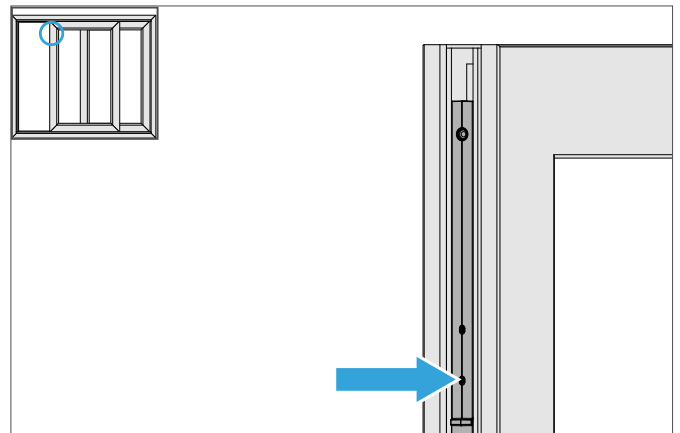

2. The reference run starts with a short press on the operator push button (cf. chapter "How it works").

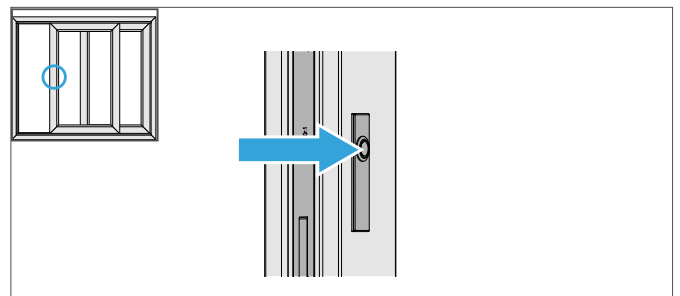

→ The sliding sash runs against the frame and locks.

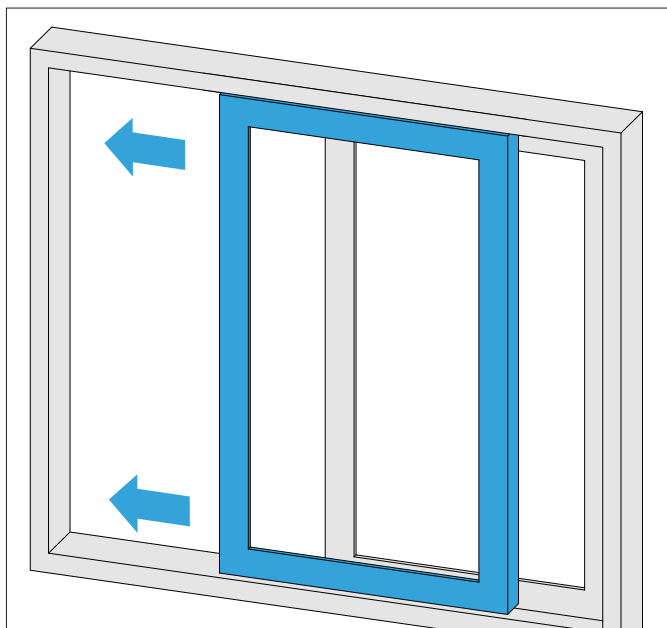

→ The reference run is successfully completed.

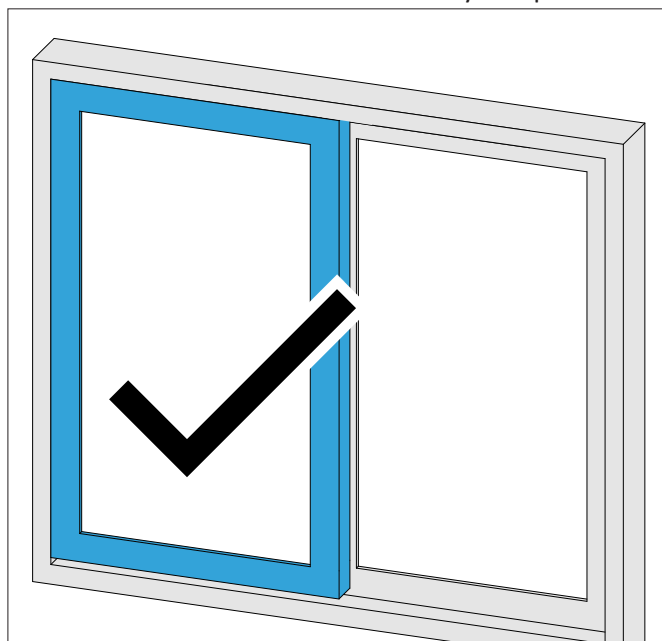

→ Using the operator push button the sliding sash can now be opened 400 mm wide and reclosed.

EN

DE

### 5.5 Not symmetrical fixed sash

#### Prerequisite

- If the fixed sash is wider than the sliding sash, a shearing zone of 25 mm has to be ensured.

1. Make an adequately cut-to-length provisional opening restrictor.

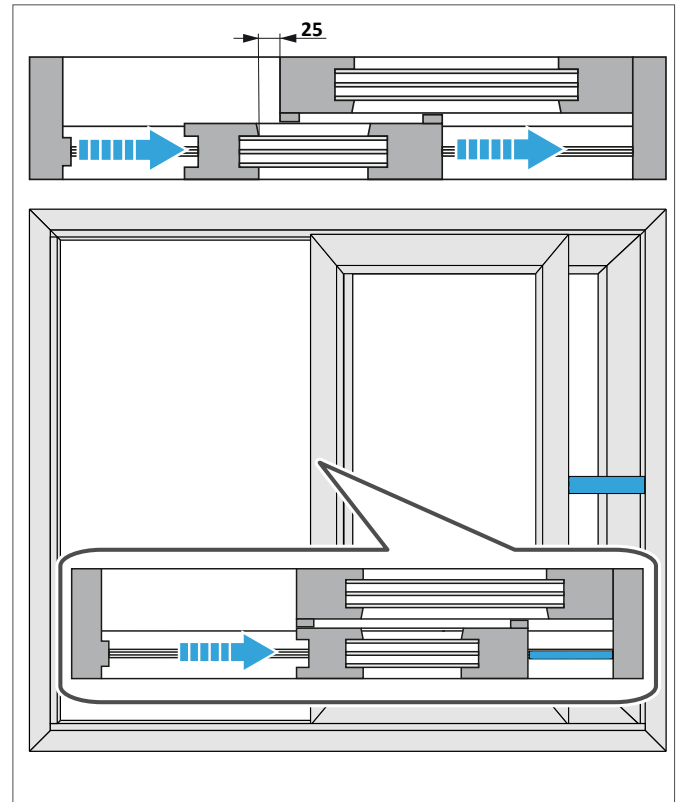

- The provisional opening restrictor has to be long enough for the open sliding sash to be flush with the fixed sash.

EN

DE

## 5.6 Performing a teach-in run

### ⚠ WARNING

#### Danger of crushing due to deactivated jam protection

During the teach-in run the jam protection is deactivated. The moving element does not react to obstacles. This means that the element can crush or shear parts of the body.

- Stay within the range of vision of the moving element.
- Maintain safety clearance from the moving element.
- Keep people away from moveable elements.

#### Prerequisites

- The lift and slide element is firmly installed in the structure, glazed and aligned.
- However the lift and slide element **must not** be connected to the power supply.
- The processor mode (cf. chapter "How it works (see page 14)") is active.

1. Switch on the battery pack with a short press on the menu button.

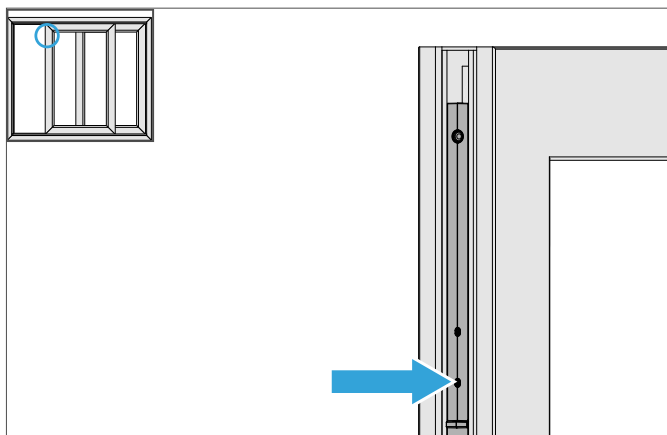

2. Start the teach-in run with a long press on the operator push button (cf. chapter "How it works (see page 12)").

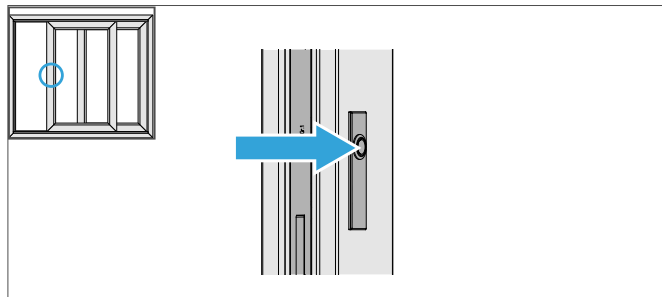

→ The sliding sash runs against the locking side and references.

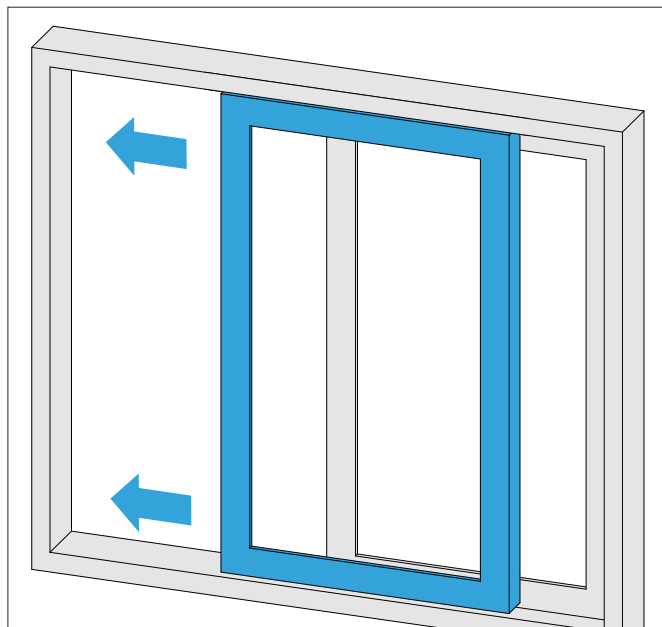

EN

DE

# Assembly instructions

DRIVE axxent LS timber elements

→ The sliding sash moves to 60 mm opening width.

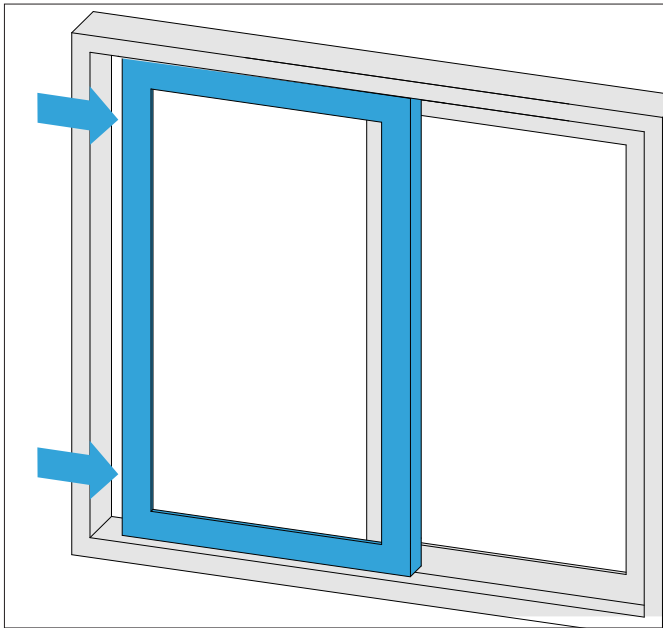

→ The sliding sash moves to the closed position and starts with the measurement runs.

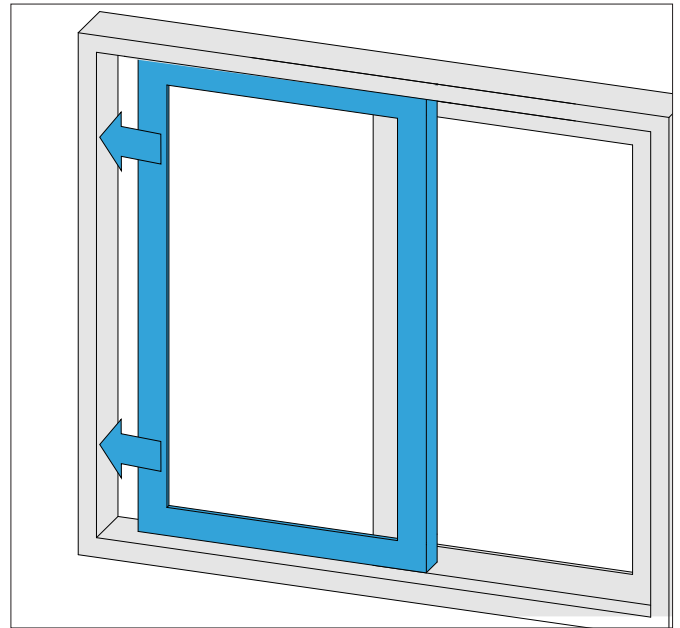

→ The sliding sash references the lift drive.

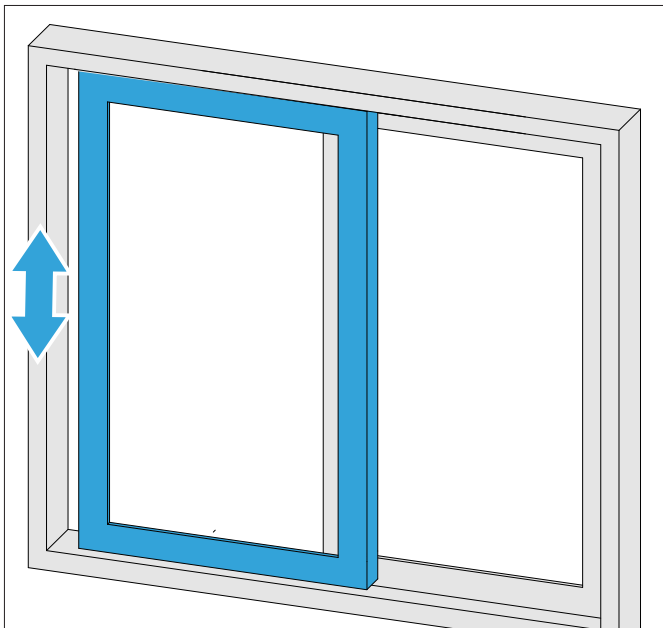

→ 2 slow measurement runs "Open" and "Closed" occur.

During the measurement runs the status LED must not light up yellow.

In addition, the status LED is accompanied by an acoustic signal.

In the event of a status LED lighting up yellow the teach-in run has not been successfully completed - even if the sliding sash does not stop.

A difficulty has to be rectified.

Restart the teach-in run.

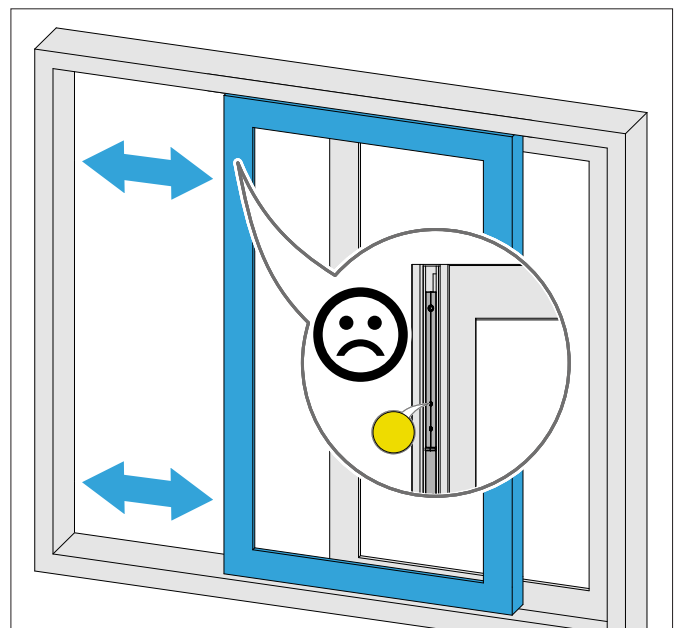

→ 2 rapid measurement runs "Open" and "Closed" occur.

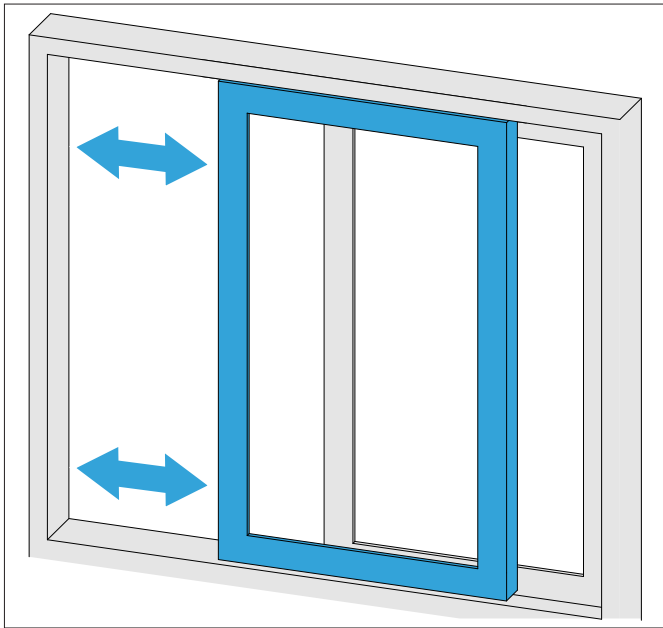

→ The sliding sash stays closed, not locked.  
The operator push button LED lights up blue.

→ The teach-in run was successful if a no difficulty was detected (the status LED does not light up yellow).  
A tone sequence is emitted.

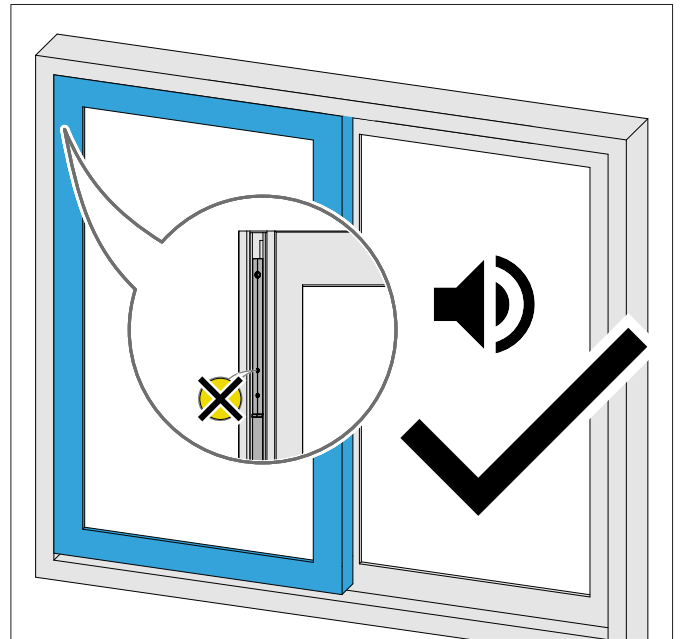

The sliding sash can now be operated with the operator push button across the entire traverse path.

## 5.7 Attaching the sticker

1. Glue the enclosed sticker onto the sliding element to be clearly visible.

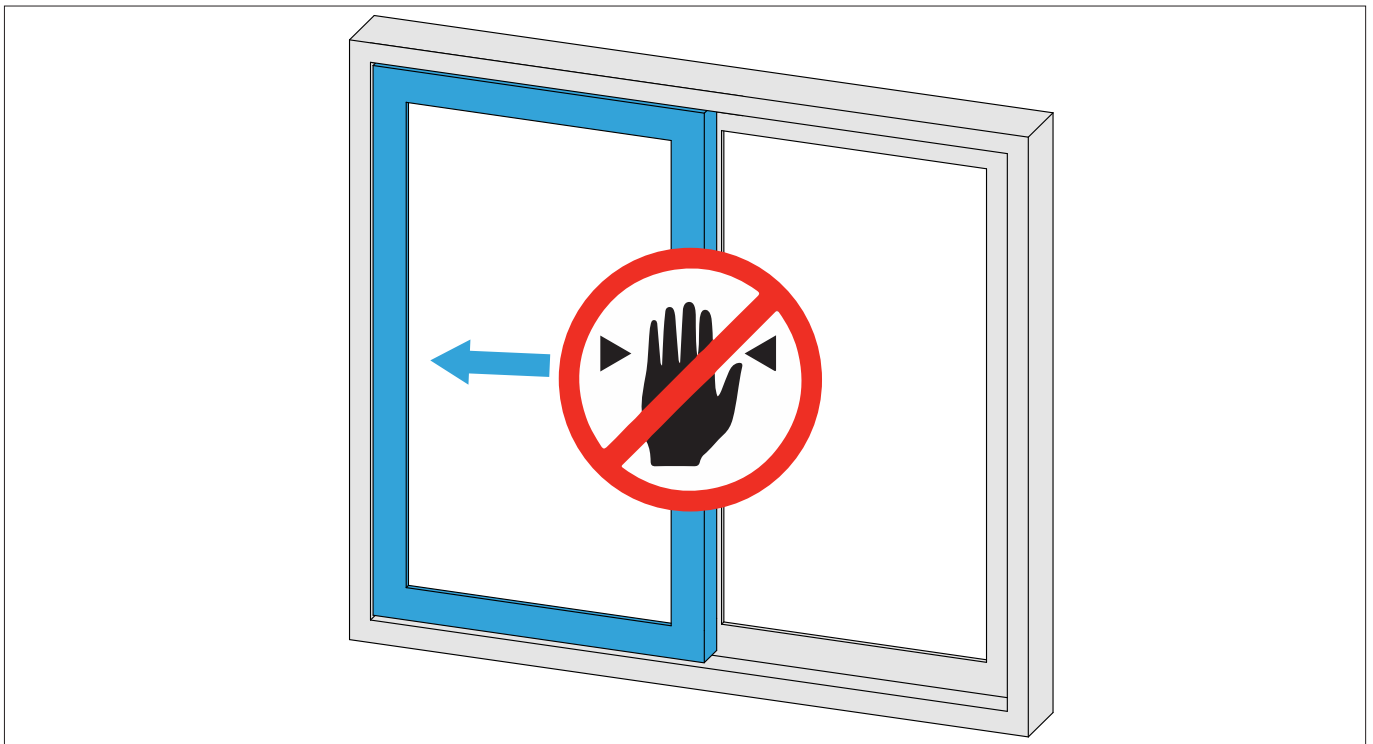

### 5.8 Transferring the lift and slide element to the installation site

To transfer the lift and slide element to the end customer put the lift and slide element in the operator mode.

The battery pack discharges within 30 hours to a charge level of 3%, provided there is no power connection.

To achieve full operability the battery pack has to be charged to a charge level of at least 20%.

The charging time is  $\pm 30$  minutes.

1. Open the sliding sash.
2. Hold down the operator push button for 10 seconds.  
→ A confirmation tone sounds and the operator mode is activated.

EN

DE

## 6 Troubleshooting

### 6.1 Troubleshooting

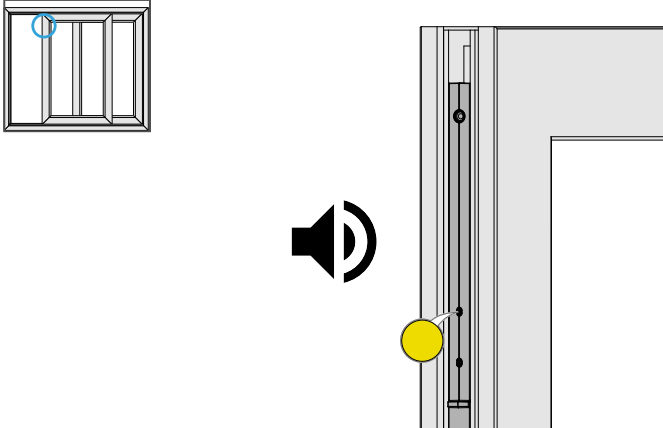
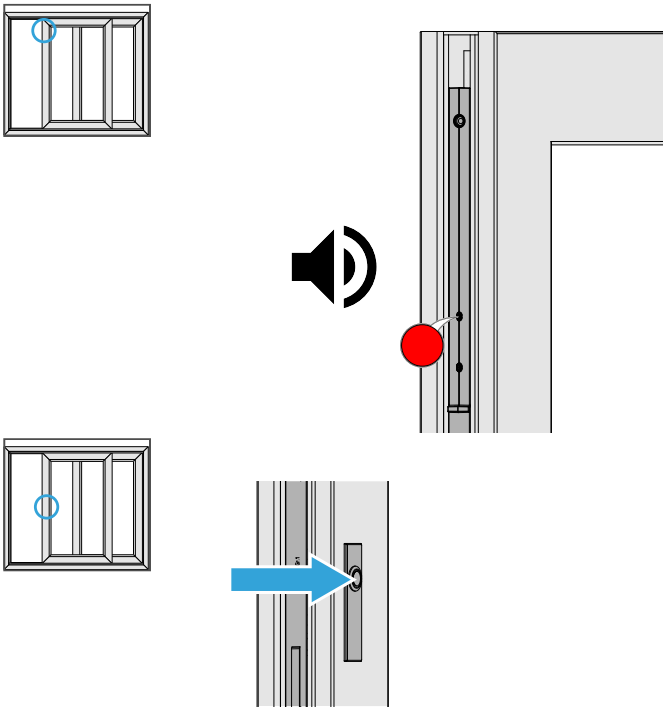
Problem	Possible cause		Solution
<p>During the first 2 slow runs of the teach-in run the status indicator LED has lit up yellow.</p>	<p>Difficulties were noticed during the measurement runs carried out in the "Teach-in run" chapter.</p> <p>The maximum displacement force of 60 N is exceeded. The status LED lights up yellow. An acoustic signal is emitted.</p> 		<p>Rectify the difficulty and restart the teach-in run. An error code is stored in the battery pack. The error code can be read in the event of a complaint.</p>
<p>During the first 2 slow runs of the teach-in run the status indicator LED has lit up red. The teach-in run was terminated.</p>	<p>Difficulties were noticed during the measurement runs carried out in the "Teach-in run" chapter.</p> <p>The displacement force is higher than 80 N. The status LED lights up red. An acoustic signal is emitted. The sliding sash stops and waits for a press of the operator push button as acknowledgement.</p> 		<p>Rectify the difficulty and restart the teach-in run.</p>

EN

DE

# Assembly instructions

## DRIVE axxent LS timber elements

Problem	Possible cause	Solution
General malfunction, implausible behaviour, there is no difficulty present.	Undefined system error	Reestablish condition at delivery, to do this please first perform the item "Factory settings" and then item "Disconnect devices" in the menu, if necessary this menu strand needs to be "enabled" again, see chapt. 3.5.3 Menu. Now continue with chapter 4.5.7 pairing battery pack with lift and slide drive.
The lift drive cannot operate on the dismantled sash.	The sash was already paired once with the slide drive.	Unpair slide drive, to do this please perform the item "Disconnect devices" in the menu, see chapt. 3.5.3 Menu.
Teach-in run cannot start.	Charge level of the battery pack too low (< 20%)	Charge battery pack, see chapter 2.2.1 and chapter 3.7.1

## 6.2 Operating limitations in case of low charge status of battery pack (battery pack runs down when sash is open)

The operational ability of the battery pack, when the sliding sash is open, is $\pm 30$ hours. In order to guarantee further operation, the battery pack indicates an automatic scenario as shown below:	
Charge status	Action
20 %	<ul style="list-style-type: none"><li>• The silent mode is active</li><li>• The sliding sash only moves slowly</li></ul>
10 %	<ul style="list-style-type: none"><li>• The sliding sash only moves to the closed position</li><li>• A warning signal tone is emitted every minute</li><li>• The status LED flashes red every minute</li></ul>
$\leq 3$ %	<ul style="list-style-type: none"><li>• The battery pack switches off (in case of no motion)</li><li>• The status LED flashes red</li><li>• The sliding sash can only be pushed into the charging contacts manually.</li><li>• It is still possible to lift and lower the sliding sash.</li><li>• Complete functioning of the sliding sash is only possible from a charge status of 20 % upwards (charging time <math>\pm 30</math> minutes)</li><li>• The complete charging of a flat battery pack lasts <math>\pm 3</math> hours</li></ul>

### 6.3 Emergency release in the event of drive failure

If the lift and slide drive fails, the sliding element can be raised and lowered manually using the emergency operating key, supplied. In the raised state the sliding element can be slowly moved by hand. **Note:** The emergency operating key is designed solely for manual operation in the event of a malfunction. Transfer the operating instructions and the emergency operating key to the customer during the commissioning.

1. Carefully release the operator push button from the sliding element.

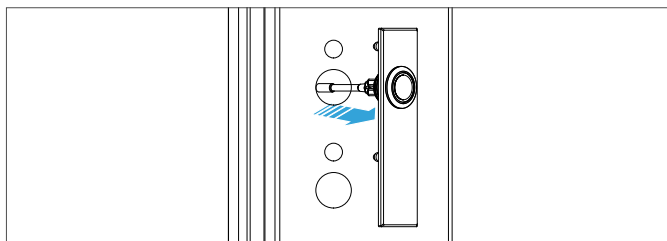

2. Insert the emergency operating key into the opening at the bottom as far as the stop.

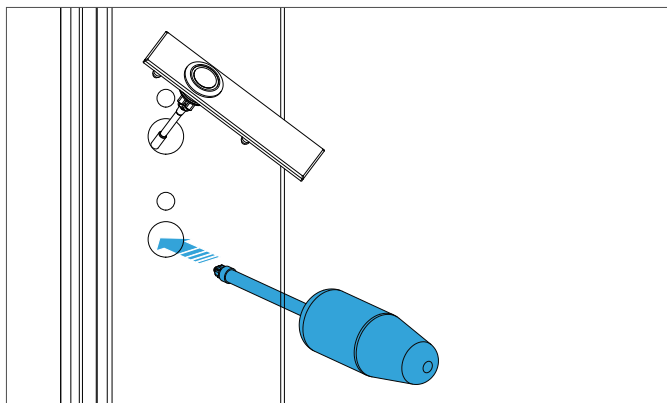

3. Turning the emergency operating key clockwise lowers the sliding element. Turning the emergency operating key anticlockwise raises the sliding element.

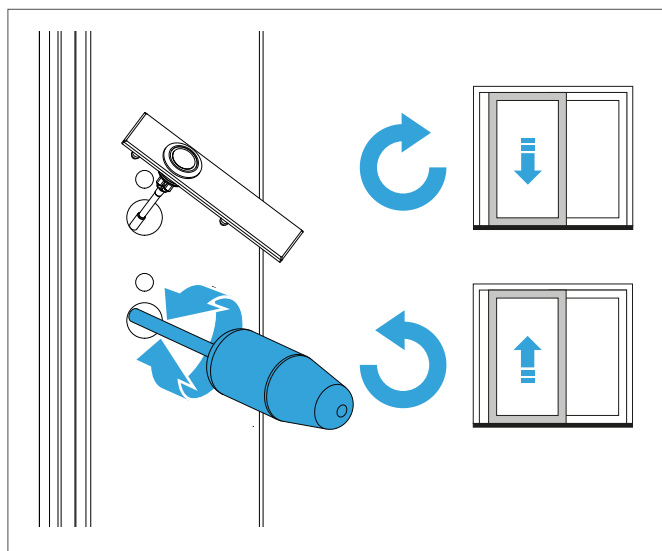

EN

DE

# Assembly instructions

DRIVE axxent LS timber elements

## 7 Compliance

### 7.1 EU Declaration of incorporation

We, the producer, hereby declare that our product complies with the following directives.

Producer	Product	
SIEGENIA-AUBI KG Industriestraße 1 – 3 57234 Wilnsdorf	Device type:	Type designation:
	Concealed lift-slide drive	DRIVE axxent LS

GUIDELINE		Harmonised standards
Machinery Directive	2006/42/EC	EN 12100:2010 EN 60335-1 (VDE 0700-1):2020-08 EN60335-1:2012+AC+A11+A13+A1+A2+A14:2019 EN 60335-1:2012/A15:2021 EN 60335-1:2012/A16:2023 EN 60335-2-103 (VDE 0700-103):2016-05 EN 60335-2-103:2015 IEC 60335-1:2010 IEC 60335-1:2010/AMD1:2013 IEC 60335-1:2010/AMD2:2016 IEC 60335-2-103:2015 IEC 60335-2-103:2015/AMD1:2017 IEC 60335-2-103:2015/AMD2:2019
EMC Directive	2014/30/EU	EN 55014-1:2021 EN 55014-2:2021 EN 301 489-1 V2.2.3 EN 61000-6-1:2019 EN 61000-3-2:2019 + A1:2021 EN 61000-6-3:2021 EN 61000-3-3:2013 + A1:2019 + A2:2021
RoHS Directive	2011/65/EU	EN 63000:2018
UN recommendation for the transport of dangerous goods		UN 38.3 Rev.7
Battery directive	2006/66/EG 2013/56/EU	IEC 62133-2:2017+A1

The incomplete machine may only be commissioned if it has been ascertained that the machine into which it is to be installed conforms to the specifications of the Machinery Directive. The specific technical documentation has been compiled in accordance with Appendix VII Part B of the EC Machinery Directive 2006/42/EC. We undertake to provide such documentation to the regulatory authorities in electronic format within a reasonable time upon a well-founded request. The aforementioned technical documentation can be obtained from the producer.

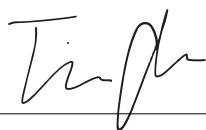

Wilnsdorf, 2024-07-23 Tim Opfer  
(Group development leader)



# Experience windows anew. Visit us at the Finstral Studio.

## **Finstral Studio Unterinn**

Headquarters, 600 m<sup>2</sup> exhibition area  
Unterinn/Ritten, Italy  
T +39 0471 296611  
[finstral.com/unterinn](https://finstral.com/unterinn)

## **Finstral Studio Borehamwood**

Showroom, 210 m<sup>2</sup> exhibition area  
Premier House, Elstree Way  
T +44 (0)20 80500584  
Borehamwood, Hertfordshire, WD6 1JH  
[finstral.com/borehamwood](https://finstral.com/borehamwood)

## **Your nearest Finstral partner:**

[finstral.com/dealer-search](https://finstral.com/dealer-search)

## **Edition January 2026**

Item number 60-0313-00-07

## **Talk directly to a specialist consultant:**

Chat online [finstral.com](https://finstral.com) or call us +44 (0)20 80500584

## **Your nearest Finstral partner:**